

# University of Florida

August 27, 2008

## First Principles Nano-Engineering of Extraordinary Organic Electroactive Materials

L. R. Dalton

George B. Kauffman Univ. Prof.  
B. Seymour Rabinovitch Chair  
University of Washington



## Fundamental Equations & Definitions

Charge perturbation and molecular organization define **electro-optic**, **photovoltaic**, **light emitting**, **electronic**, and **photorefractive** behavior. We want to understand charge perturbation and transport and how intermolecular electrostatic interactions define molecular organization from first principles theory. **Use Electro-Optics as example.**

**Starting point:** Power series expansion in terms of E field:

$$\mu_i(\mathbf{E}) = \mu_i(0) + \alpha_{ij}E_j + (1/2!)\beta_{ijk}E_jE_k + (1/3!)\gamma_{ijkl}E_jE_kE_l + \dots$$

$\mu_i(0)$  is the permanent dipole moment,  $\alpha_{ij}$  is the linear polarizability,  $\beta_{ijk}$  is molecular first hyperpolarizability,  $\gamma_{ijkl}$  is molecular second hyperpolarizability ...

$$P_i(\mathbf{E}) = P_i(0) + \chi^{(1)}_{ij}E_j + \chi^{(2)}_{ijk}E_jE_k + \chi^{(3)}_{ijkl}E_jE_kE_l \dots$$

$P_i(0)$  is the intrinsic static dipole-moment density of the sample,  $\chi^{(1)}_{ij}$  is the linear susceptibility,  $\chi^{(2)}_{ijk}$  is the second order nonlinear linear susceptibility ...

# What Are **Electro-Optic Materials**?

⇒ **Materials with a voltage-controlled index of refraction**

Example: You apply an electric field and that field alters the charge distribution of the material, which, in turn, influences the propagation of light through the material (Pockel's effect). The reverse process is called optical rectification. **Two fields involved—2<sup>nd</sup> order nonlinear optical effect.**

⇒ **Types of EO Materials (speed relates to mass moved)**

**Liquid Crystalline (LC) Materials—Change in molecular orientation.**

- Very big effect (>10,000 pm/V) but slow ( $10^{-3}$ - $10^{-6}$  sec)

**Inorganic Crystals—Ion displacement.**

- Small effect (30 pm/V) but faster ( $10^{-10}$  sec)

**$\pi$ -Electron chromophore-containing polymers/dendrimers—  
Change in  $\pi$ -electron distribution**

- Big effect (>500 pm/V) and very fast ( $10^{-14}$  sec)

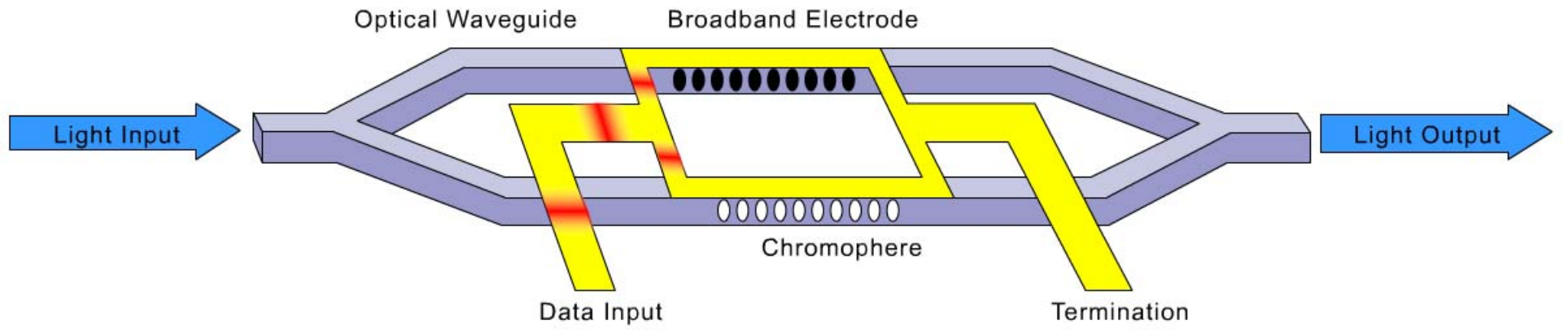

# Why Are **Electro-Optic Materials** Interesting?

## Societal Impact: NSF & DSB Workshops

Central to transduction of signals between electrical and optical domains; also permits the generation, detection, and steering of electrical and optical signals. **Key to the Next Great Thing: Photonic/Electronic Integration**—Impacts Computing, Telecommunications, Transportation, Medicine, Entertainment. Drivers: SWaP, Performance, Reliability, Cost.

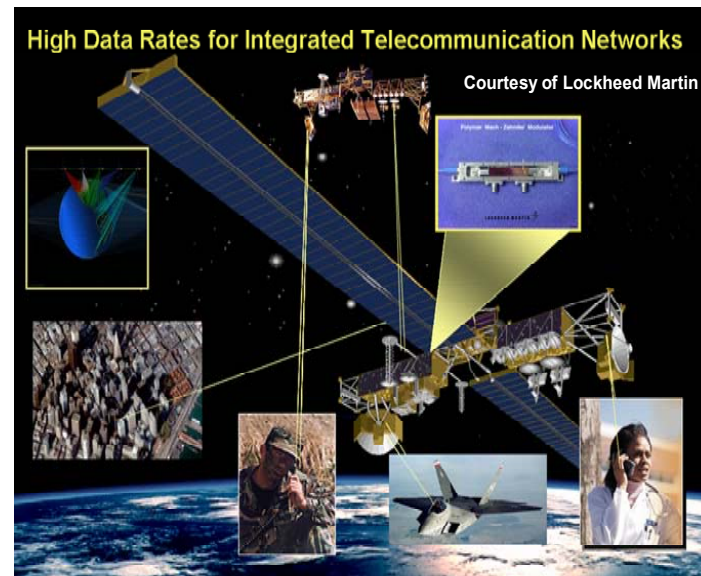
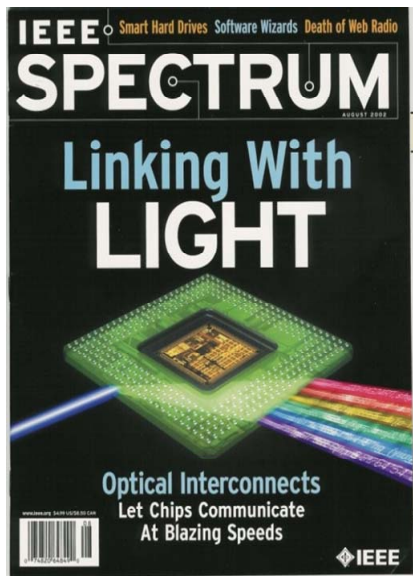

## Intellectual Merit:

**Requires high order**—essentially an issue of “crystal engineering” but retaining processability is critical. If we can “nano-engineer” EO materials from first principles, we have defined the “designer toolset” for nanotechnology. Critical for organic photovoltaics, electronics, light emitting displays, etc.

# Charge displacement can occur over extended distances using materials with extended $\pi$ -conjugation

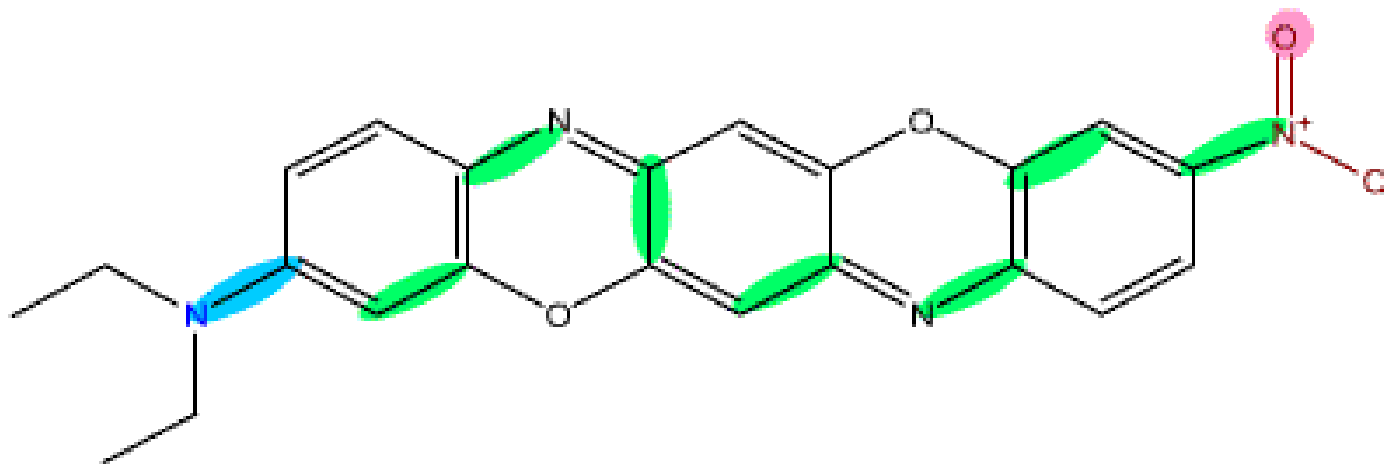

The charge separated form will have a larger dipole moment and thus a stronger interaction with an applied electric field

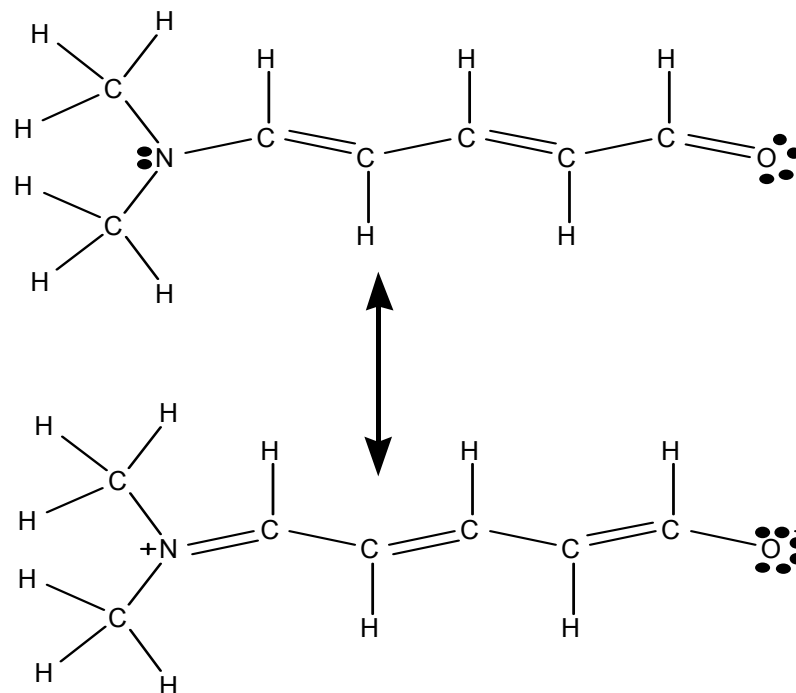

# ONLO Chromophores of the D-B-A type

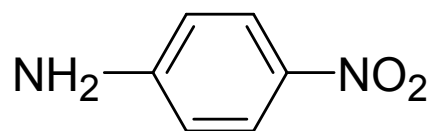

**PNA**

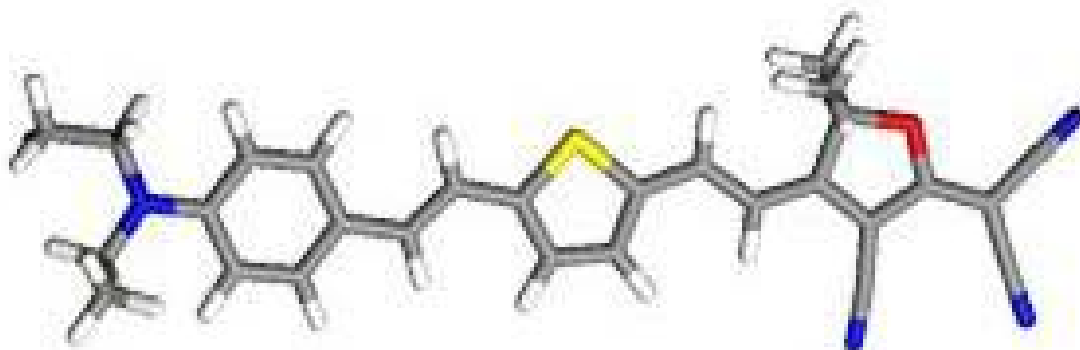
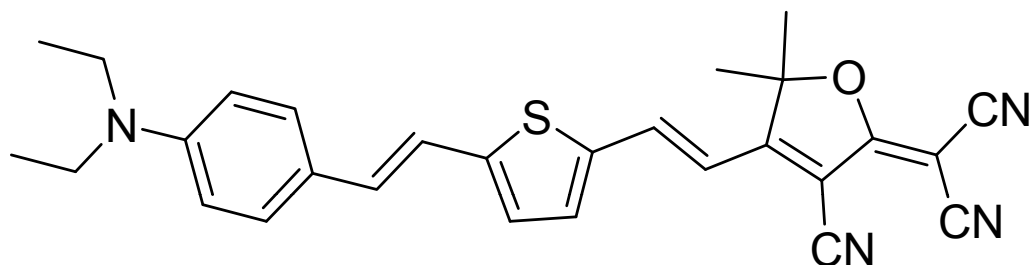

**FTC**

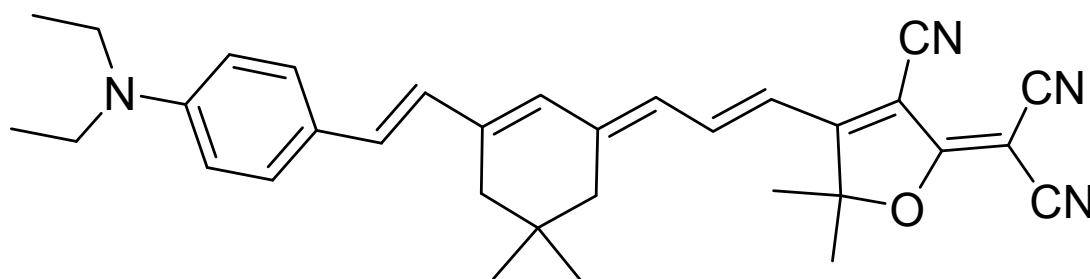

**CLD**

# FTC Chromophore and as part of a multi-chromophore containing dendrimer

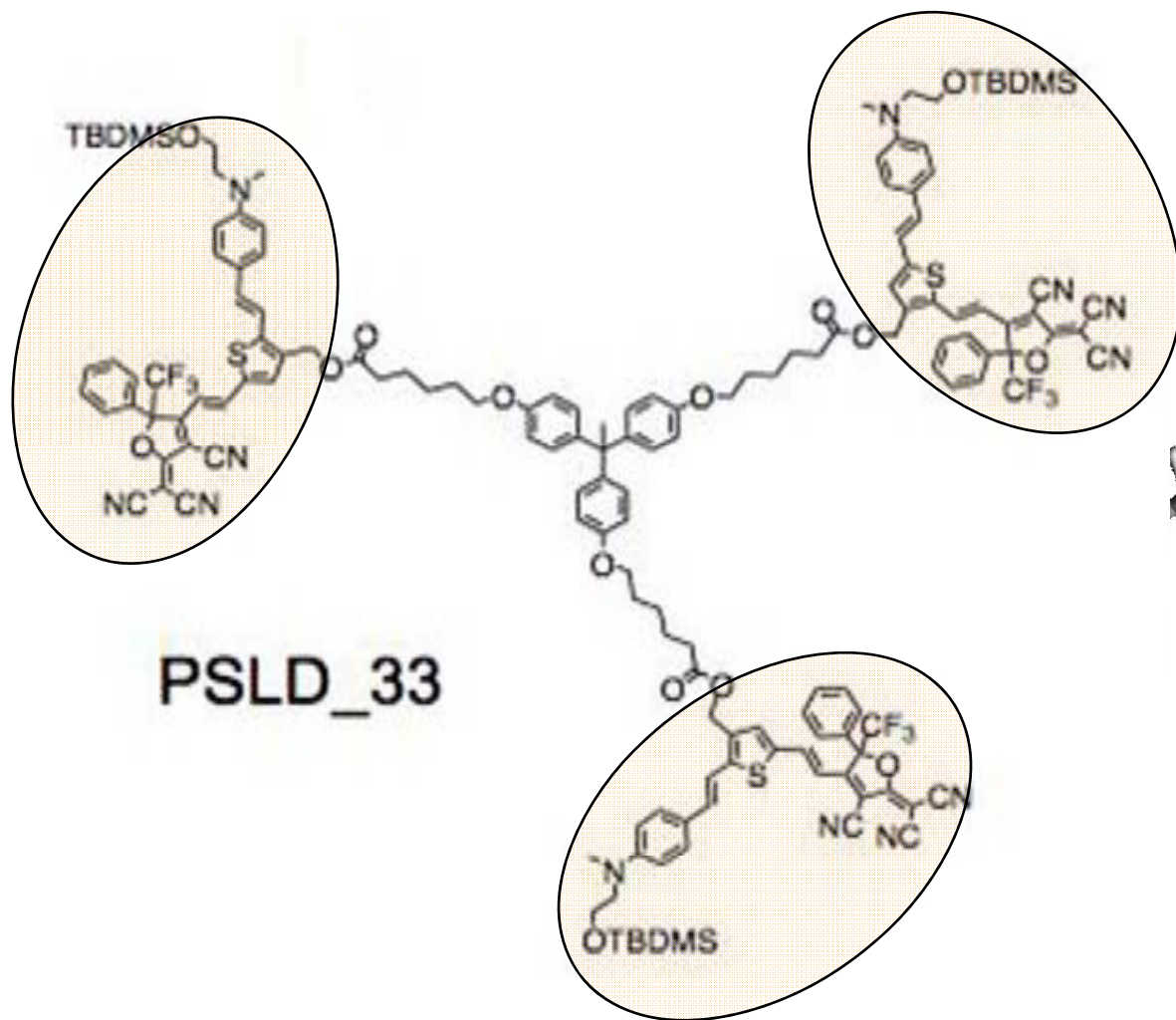

**Push-Pull Chromophore**

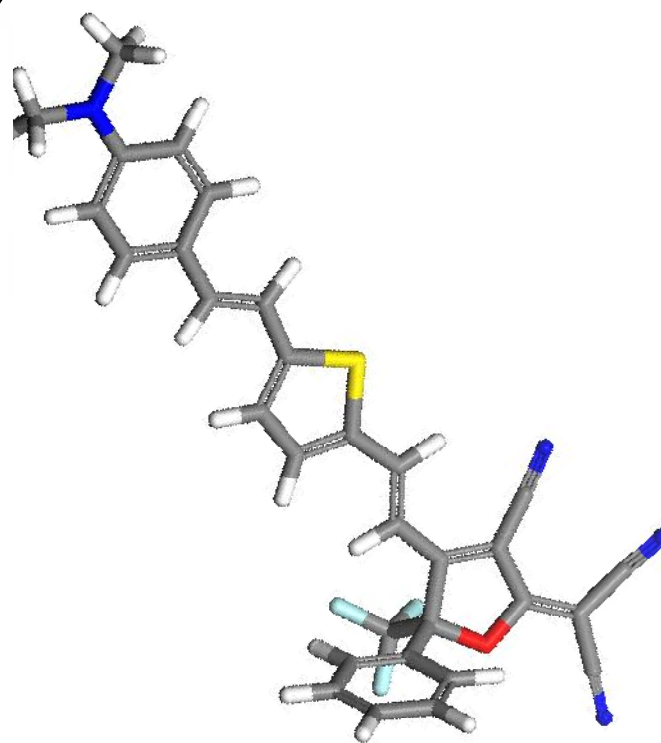

**Chromophore as part of a dendritic system**

# Optimization of Electro-Optic Activity

## *Three Types of Organic EO Materials*

- Chromophore/polymer composite materials
  - Analytical and Monte Carlo methods establish **chromophore shape** as the critical parameter
- Chromophore-containing dendrimer and dendronized polymer materials
  - Pseudo-atomistic Monte Carlo methods establish the importance of **covalent bond potentials** for optimization of EO activity
- Chromophore-doped (binary) EO organic glasses (new)
  - Chromophore host-chromophore guest interactions** critical—favorable enthalpy & entropy

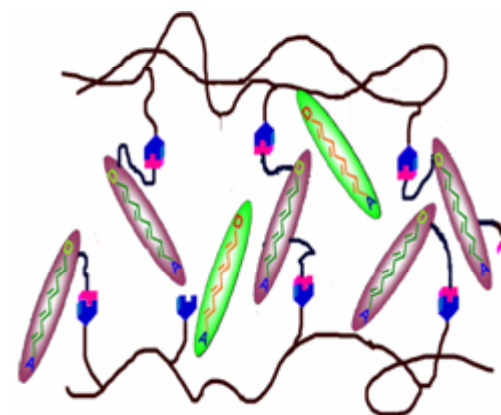

# Order Parameters and Electro-optic Coefficients

Organic chromophores are approximately axially symmetric so only two non-zero EO tensor elements which are related to two order parameters

$$r_{33} = 2\beta_{zzz}F_L(\omega)N\langle\cos^3\theta\rangle$$

$$r_{13} = \beta_{zzz}F_L(\omega)N\langle\sin^2\theta\cos\theta\rangle$$

$$\langle\cos^3\theta\rangle = \langle\cos\theta\rangle - \langle\sin^2\theta\cos\theta\rangle$$

$$\frac{r_{13}}{r_{33}} = \frac{1}{2}\left\{\frac{\langle\cos\theta\rangle}{\langle\cos^3\theta\rangle} - 1\right\}$$

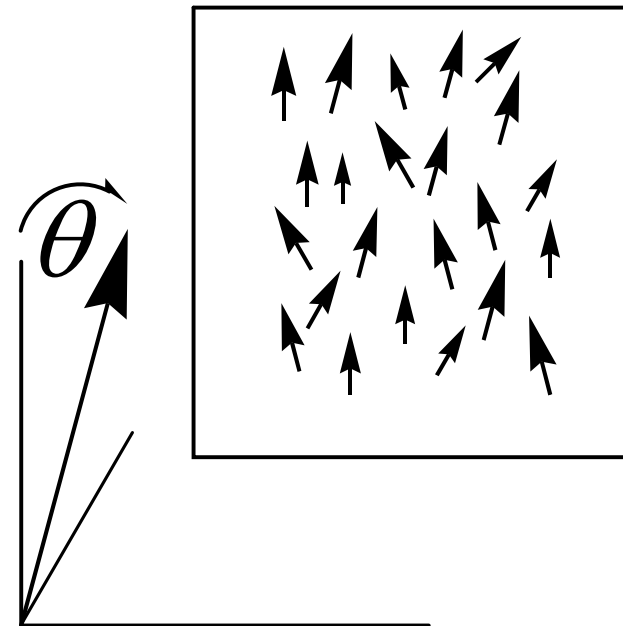

# Types of Dimensionality of Order

There are 3 basic types of order due to rotation:

| Cartesian Dimension | Order Name | Possible Positions          |
|---------------------|------------|-----------------------------|
| 1-D                 | Ising      | Point up or down on x       |
| 2-D                 | Bessel     | Rotate freely in x-y plane  |
| 3-D                 | Langevin   | Rotate freely in x,y and z. |

# The Role of Lattice Symmetry

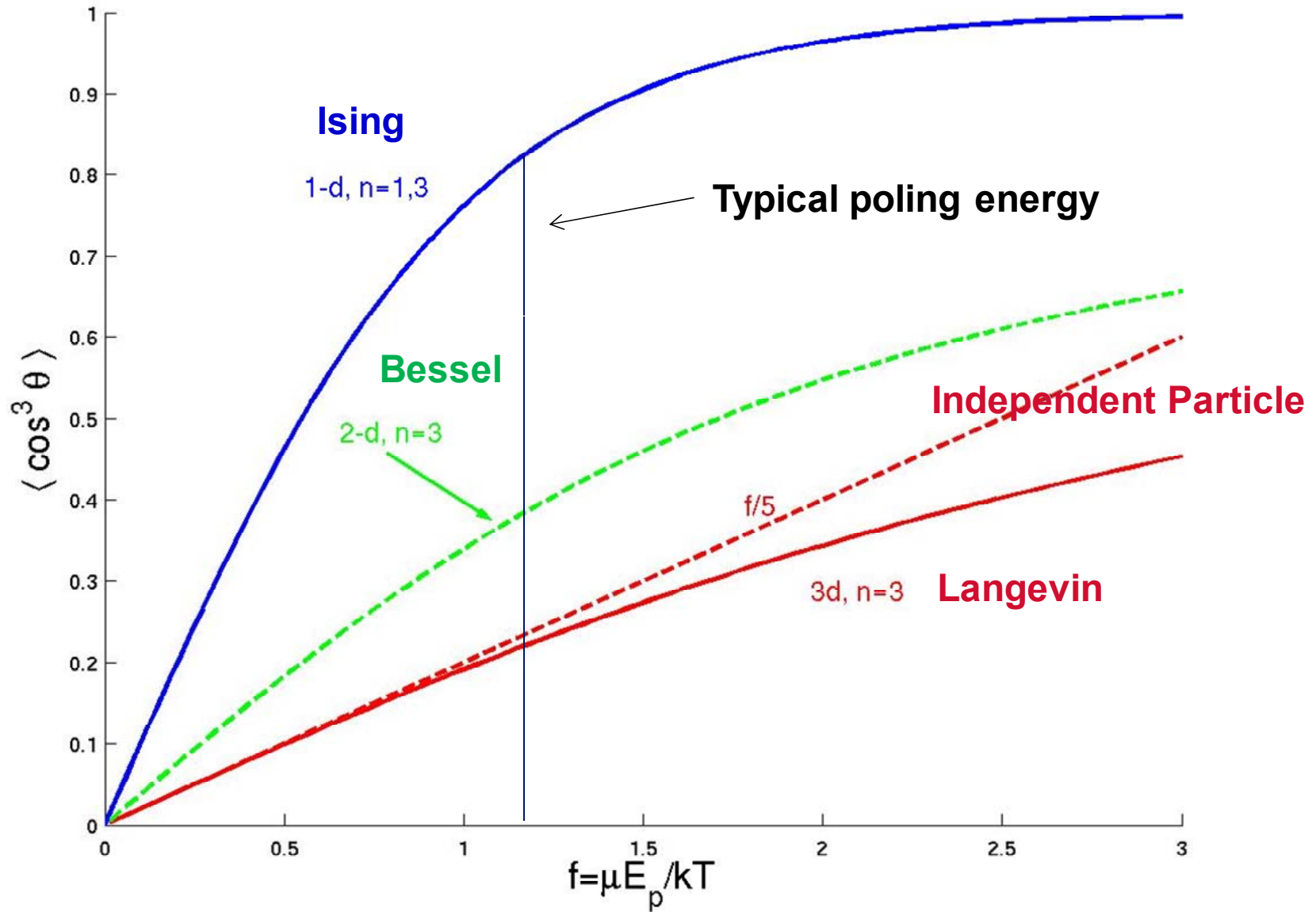

# Transformative Development of Nonlinear Optical Materials: Exceeds Moore's Law Rate

BCOG = Binary Chromophore Organic Glass

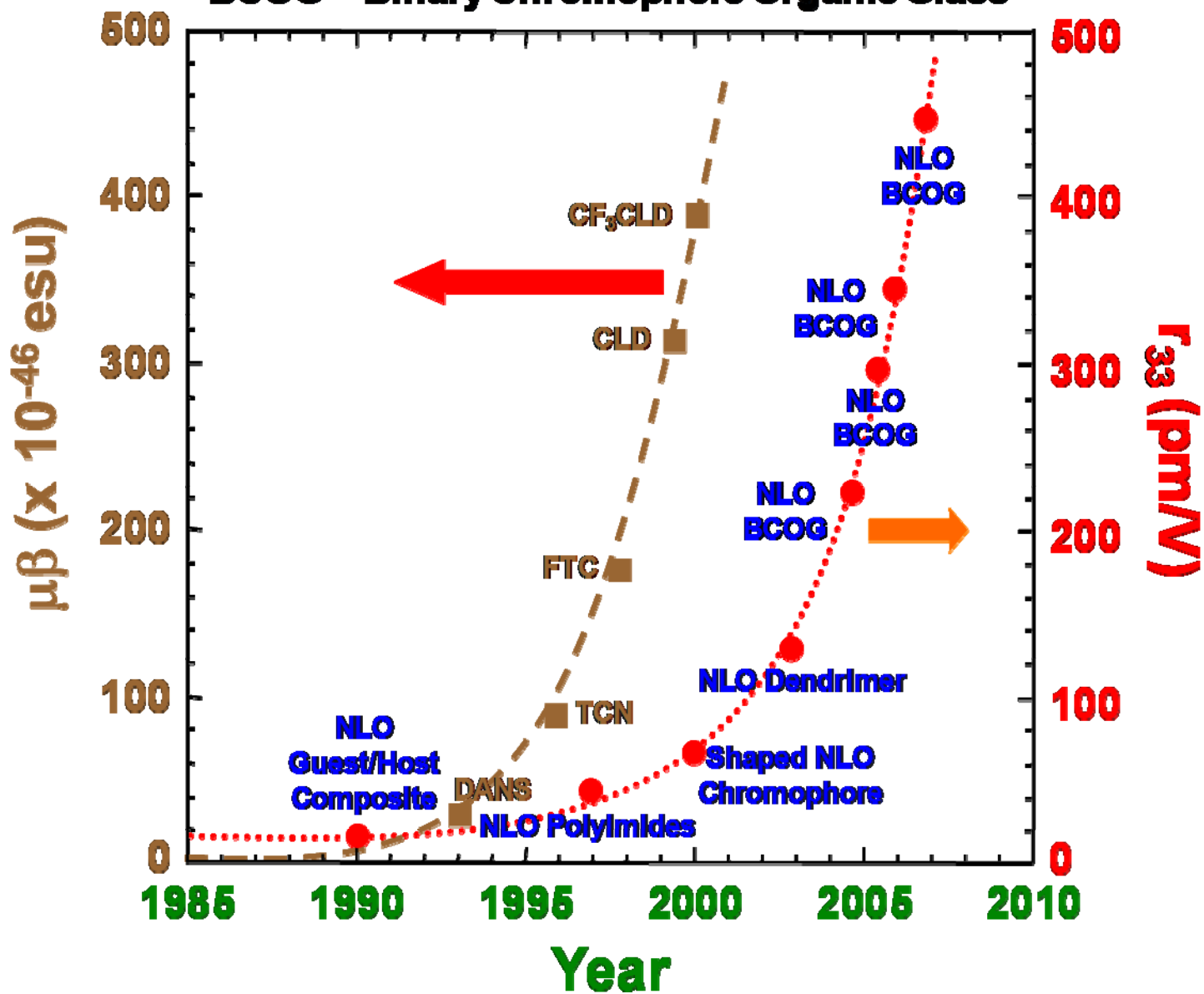
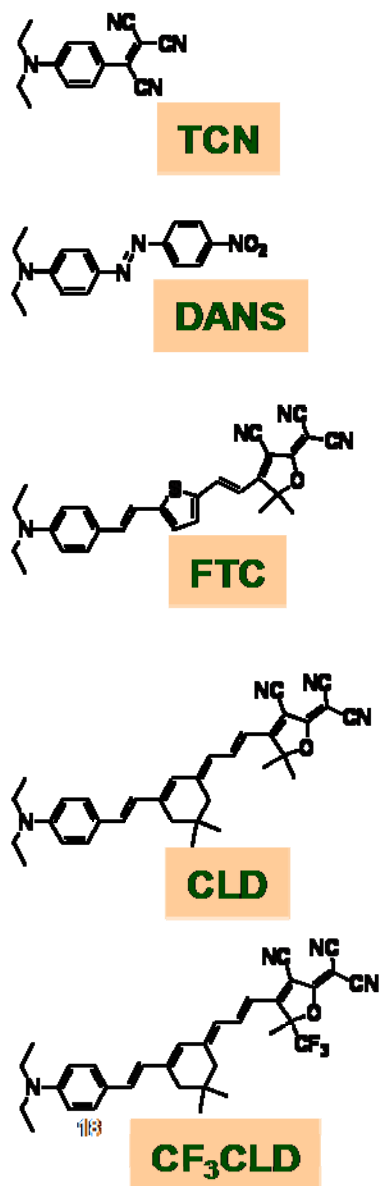

# Theory-Guided Design

Nano-  
engineering at  
all levels—  
Materials to  
Devices

Nano-structured  
Electro-Optic  
Materials

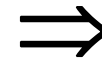

Hybrid Organic  
EO/Silicon Nano-  
Photonic Devices

$$r_{33} = \beta(\epsilon, \omega) N \langle \cos^3 \theta \rangle \text{ (constant)}$$

**Quantum Mechanics:**  
RTTD-DFT calculations to  
calculate molecular linear  
& nonlinear optical  
properties and charge  
distributions



**Statistical Mechanics:**  
Pseudo-atomistic Monte  
Carlo/Molecular Dynamic  
Calculations to compute  
chromophore order and  
reaction fields



# EO response Calculated from First Principles

$$r_{33} = 2F_{LN} \beta_{zzz} (-\omega; 0, \omega) \langle \cos^3 \theta \rangle$$

## Quantum Theory – Compute Optical Properties

- In Vacuo (Many Methods)
- Chromophore Environment (Dielectric,  $\epsilon_\omega$ )
- Frequency of Light  $\omega$  (Resonance Enhancement)

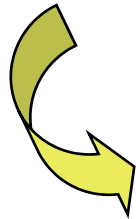

## Molecular Modeling

- Force Fields derived from QM Calculations
- United Atom and Coarse Grained Approximations

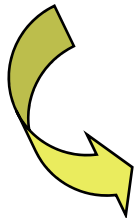

## Statistical Mechanics (describe Self-Assembly)

- Dipolar (partial charge) interactions
- Poling Field interactions
- Polarizability (linear)
- Medium Dielectric
- Van der Waals interactions (other steric effects)

# Quantum Mechanics: The Selection Problem

Which Method?

Semi-empirical  
Hartree-Fock  
MPn  
CC  
DFT  
TD-DFT

Which Basis Set?

Gaussian  
Numerical  
Pseudo-potential

Given a choice, how good is it?

# Comparison of Various Theoretical Methods for Predicting Trends

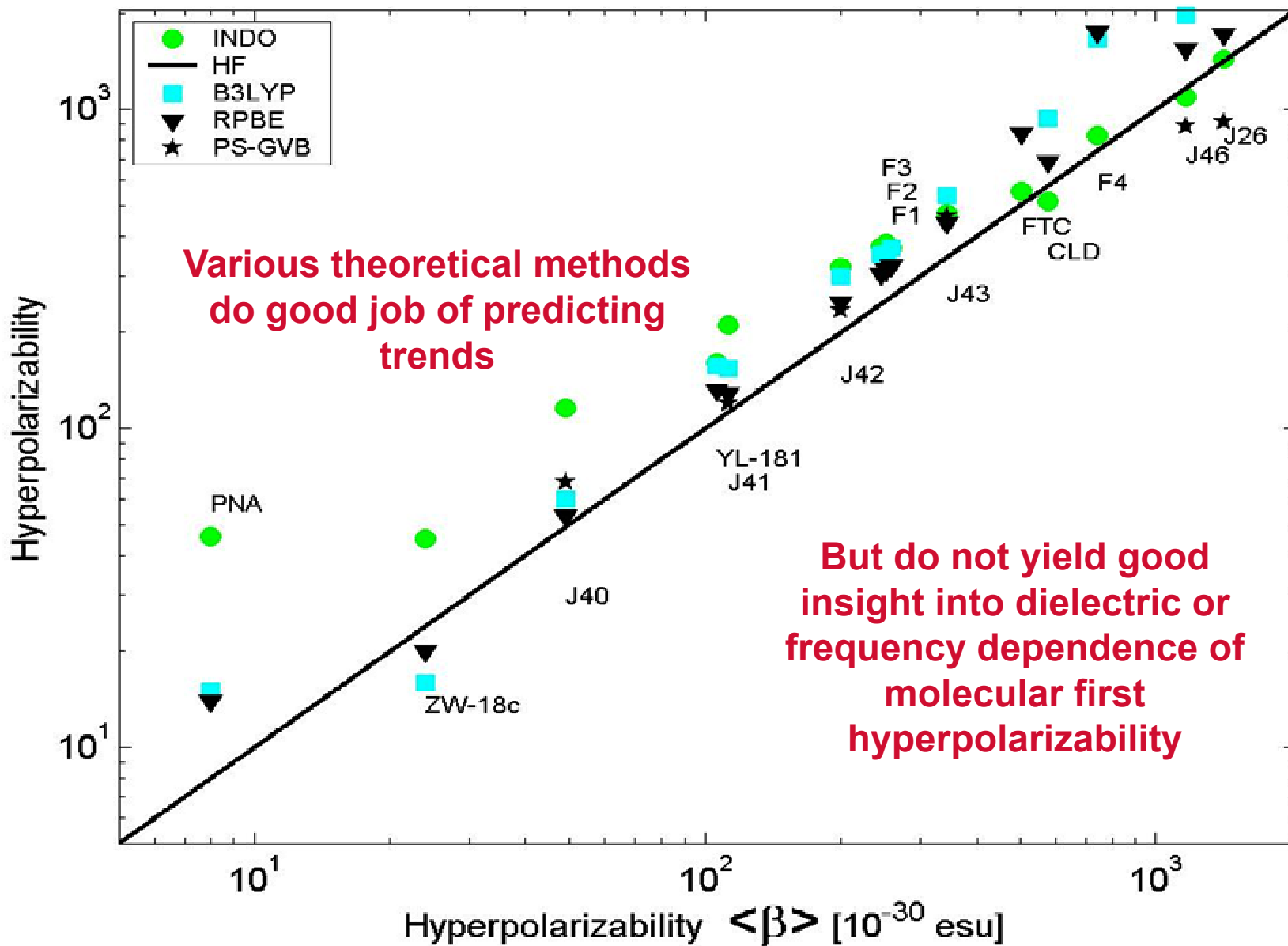

# Real Time TDDFT (RT-TDDFT)

--treatment of time-dependent electric fields--

- **Method:** extension of real-time Density Functional Theory (DFT) [Tsolakidis *et al. Phys. Rev. B* 66, 235416 (2002)] using SIESTA.
- **Real-time approach:** direct numerical integration of time-dependent Kohn-Sham DFT equations

where

$$i\frac{\partial\Psi}{\partial t} = H(t)\Psi$$

$$H = -\frac{1}{2}\nabla^2 + V_{ext}(\mathbf{r}, t) + V_H[\rho](\mathbf{r}, t) + V_{xc}[\rho](\mathbf{r}, t)$$

- **Linear and nonlinear response of a system to the external field is determined by applying a time dependent electric field**  
 $\Delta H(t) = -\mathbf{E}(t)\cdot\mathbf{x}$ .
- **At each time step, the total charge density  $\rho(\mathbf{r}, t)$  is updated.**

# Comparison of Theory and Experiment

## PNA

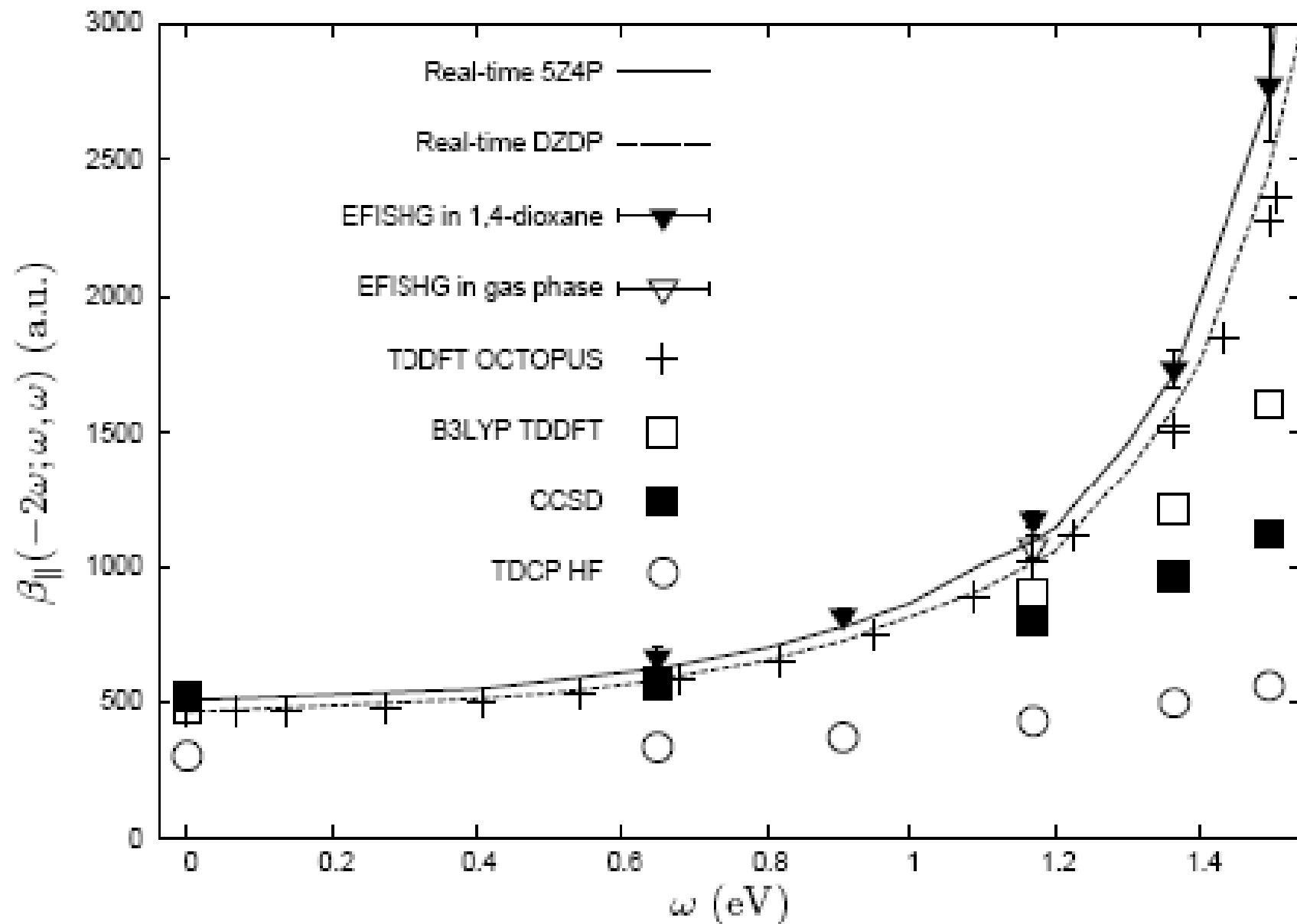

# Successful Prediction of Linear and Nonlinear Optical Properties

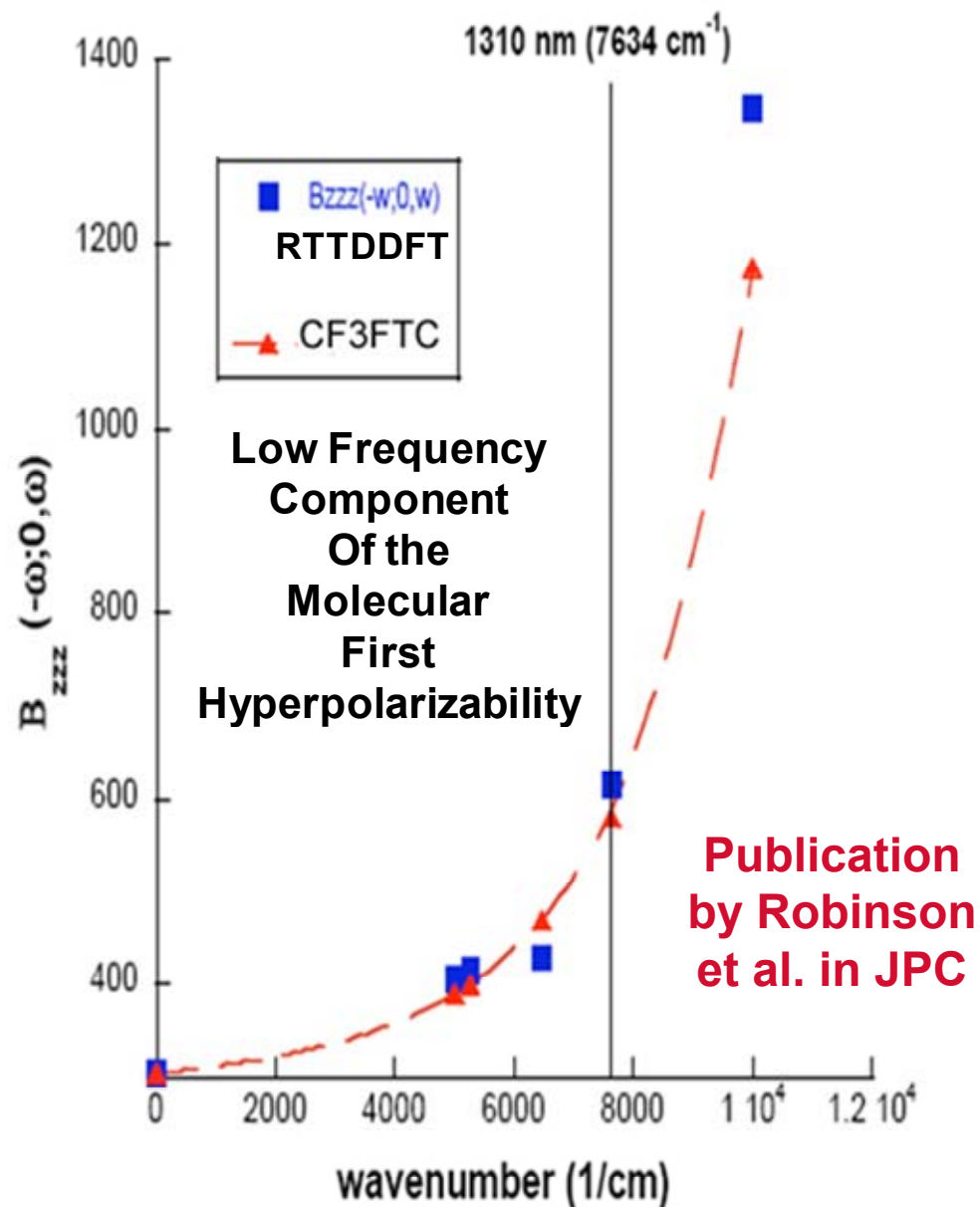
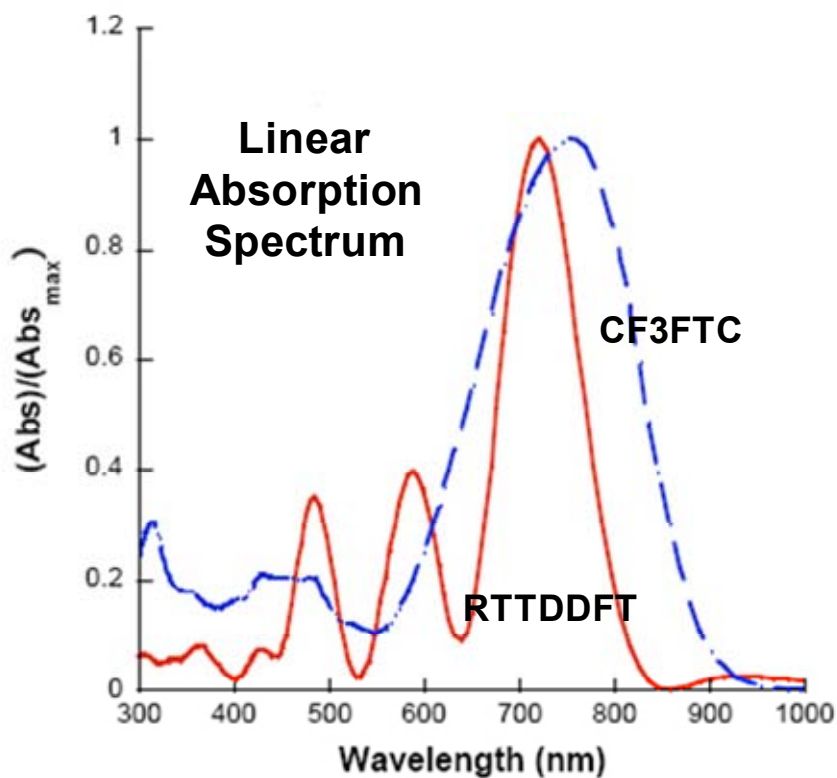
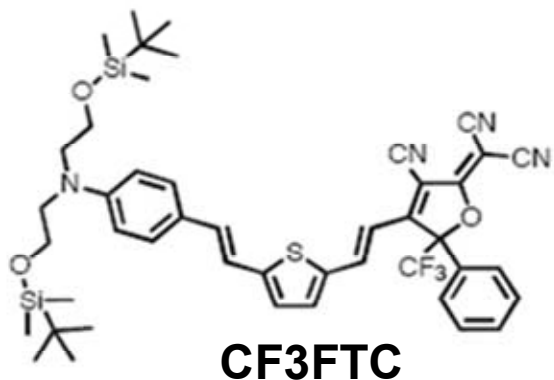

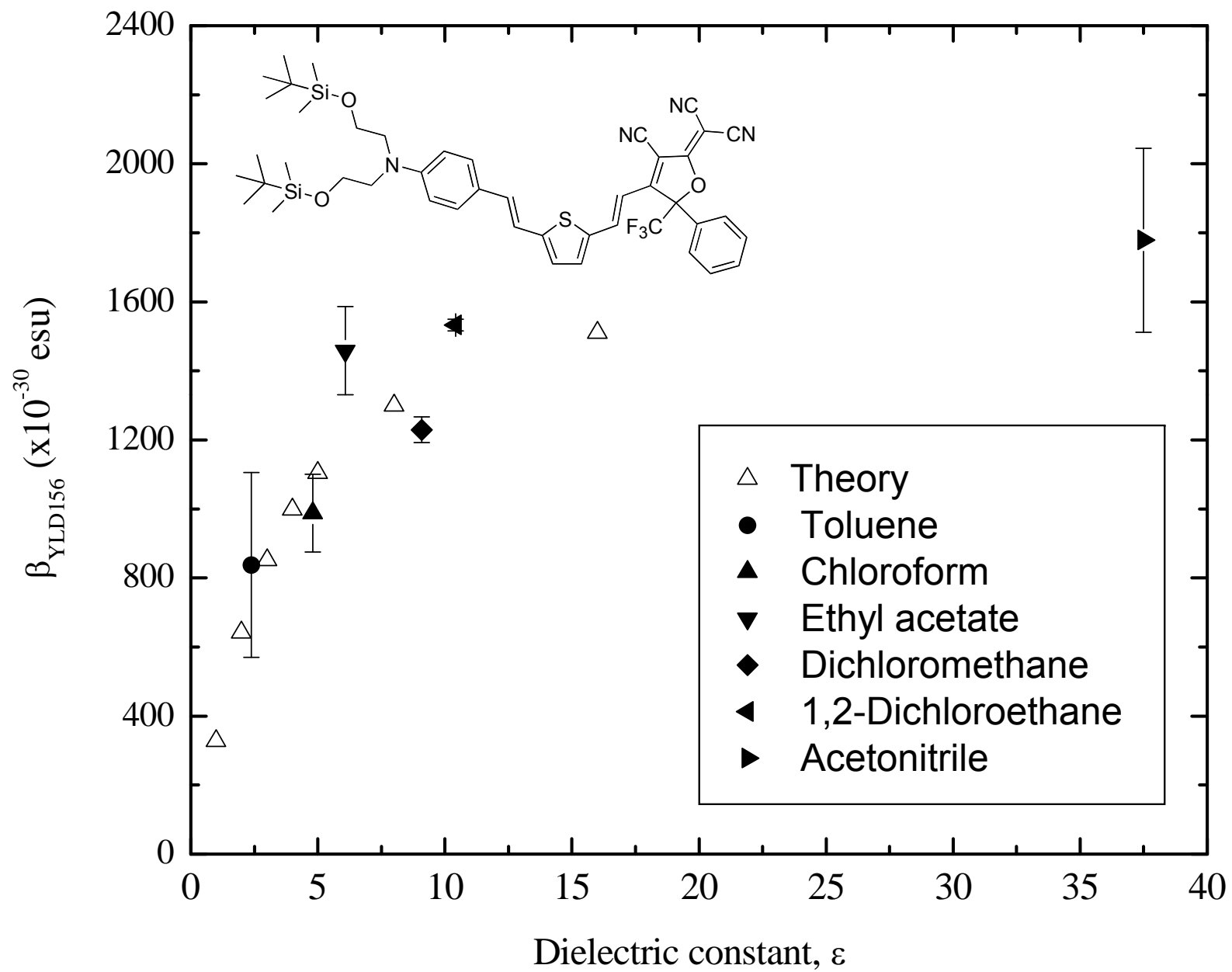

## Comparison of Theory and Experiment for Dielectric Dependence of $\mu\beta$

EFISH data on EZ-FTC

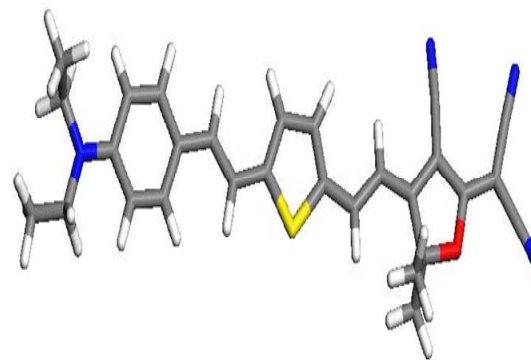

| Solvent    | $\epsilon$ | $\lambda_{\max}/\text{nm}$ | $\mu\beta_{\omega}/10^{-69}$<br>SI (exp.) | $\mu\beta_{\omega}/10^{-44}$<br>esu(exp.) | $\mu\beta_{\omega}/10^{-44}$<br>esu(theory) |
|------------|------------|----------------------------|---|---|---|
| Dioxane    | 2.21       | 622                        | 9291                                      | 3.41                                      | 4.9   |
| Chloroform | 4.81       | 675                        | 27280                                     | 8.52                                      | 8.9   |

# Electric Field Poling of Thin Film Materials to Induced EO Activity (Noncentrosymmetric Symmetry)

A DC poling field is applied across the chromophore / host matrix heated to its glass transition temperature

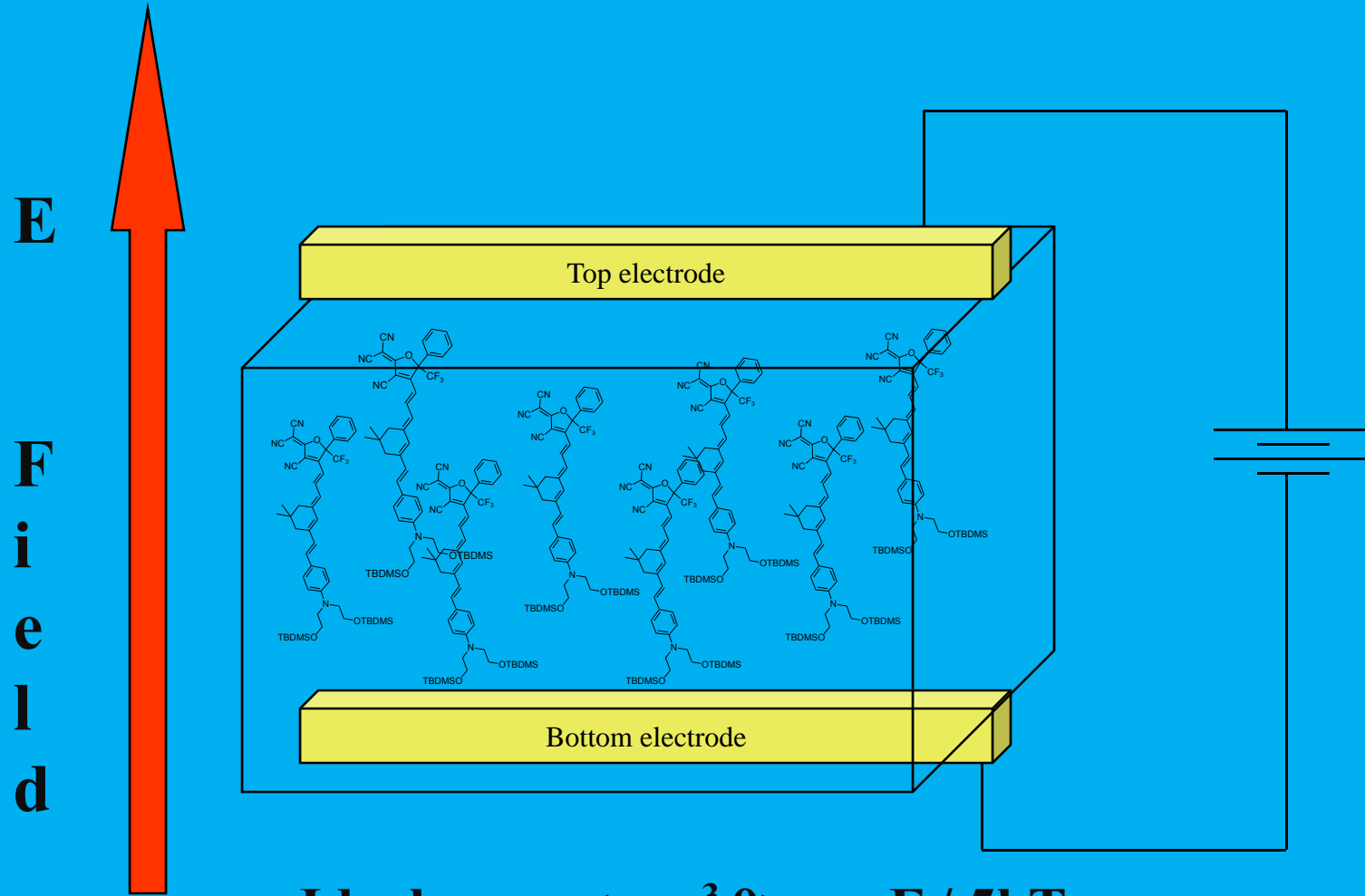

$$\text{Ideal case: } \langle \cos^3 \theta \rangle = \mu F / 5kT$$

# NONCENTROSYMMETRIC SYMMETRY REQUIRED FOR ELECTRO-OPTIC ACTIVITY

Translating Microscopic to Macroscopic Electro-Optic Activity ( $r_{33}$ )

$$r_{33} = \beta N \langle \cos^3 \theta \rangle (\text{constant})$$

$\beta$  = molecular first hyperpolarizability

$N$  = chromophore number density

$\langle \cos^3 \theta \rangle$  = acentric order parameter

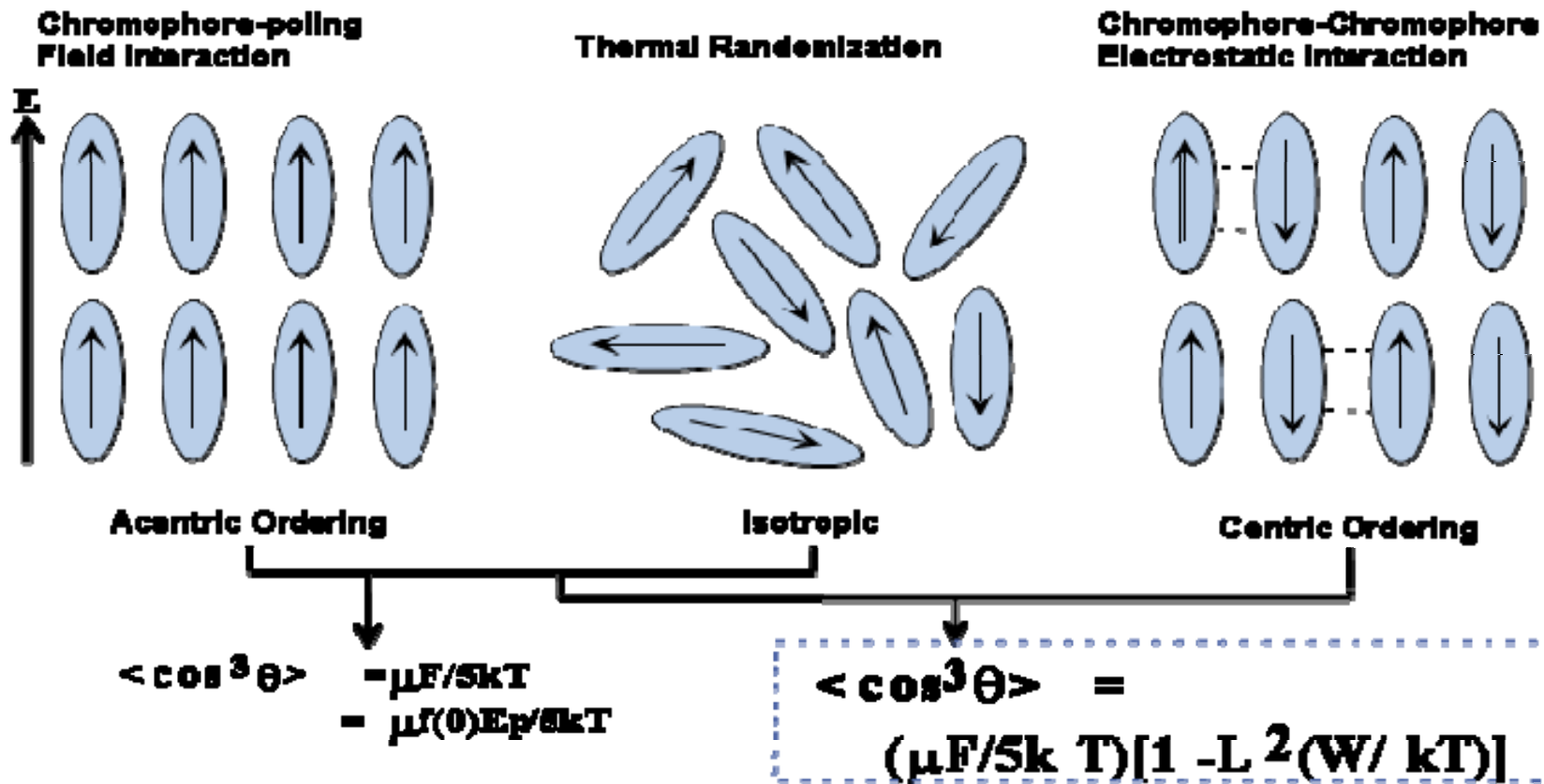

L = Langevin Function; W = Intermolecular Electrostatic Potential; k = Boltzmann constant;  $E_p$  is applied poling field; F is poling field felt by chromophore

# Activity vs. Concentration: Theory & Experiment

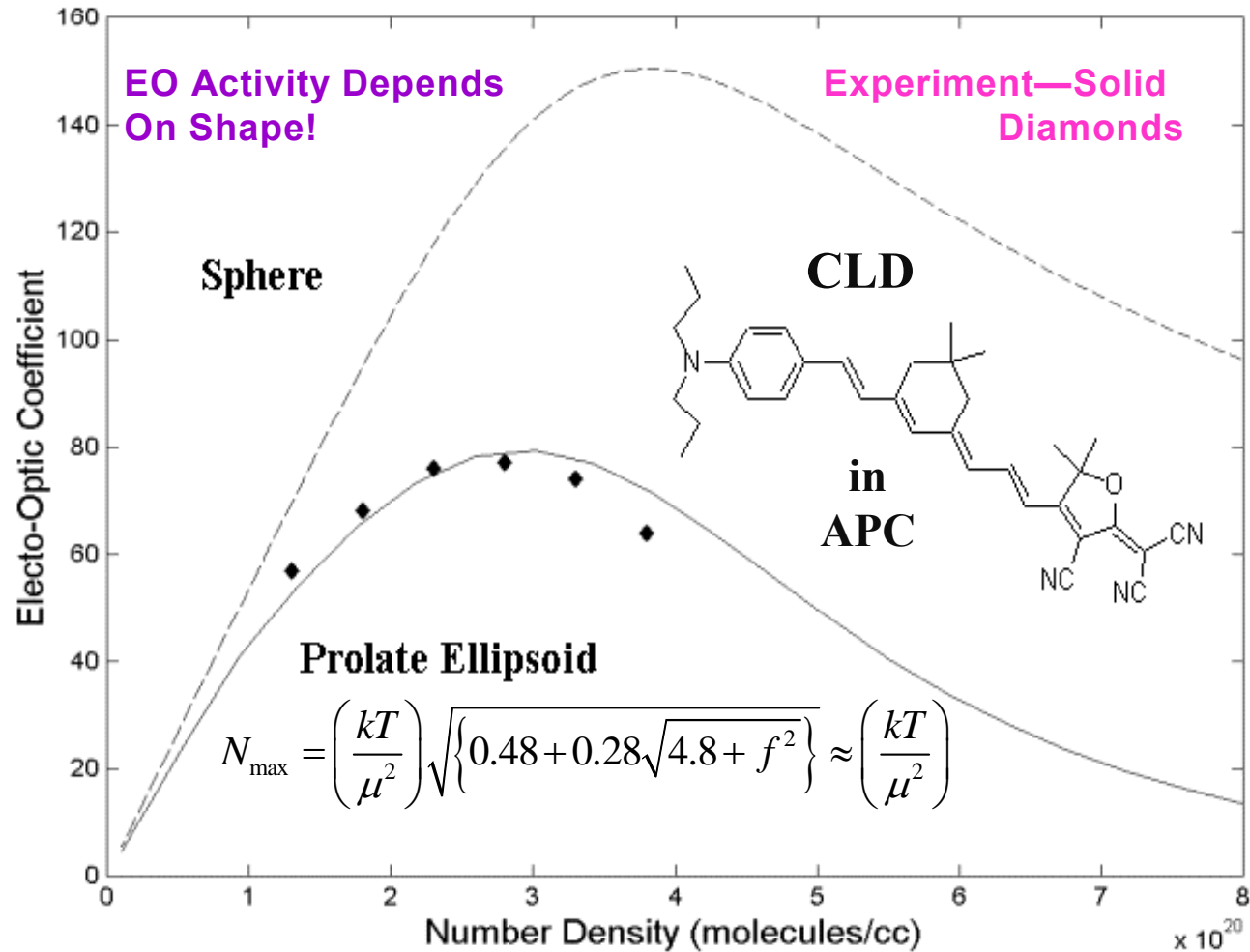

Statistical mechanical calculations permit understanding the role that **chromophore shape** has on macroscopic electro-optic activity

# Two Components of the Electronic Dipole-Dipole Interaction

- ▶ **One component (approach along the poles) favors noncentrosymmetric order while the second component (approach along the equator) favors centrosymmetric order.**
- ▶ **In the point dipole approximation, the second wins.**
- ▶ **Steric (nuclear repulsive) interactions can be used to alter the balance between these two order forces.**

# Pseudo-Atomistic Monte Carlo Calculations of $N\langle\cos^3\theta\rangle$

United Atom approach to NLO Chromophore and other p-conjugated molecules

**Chromophore: FTC**

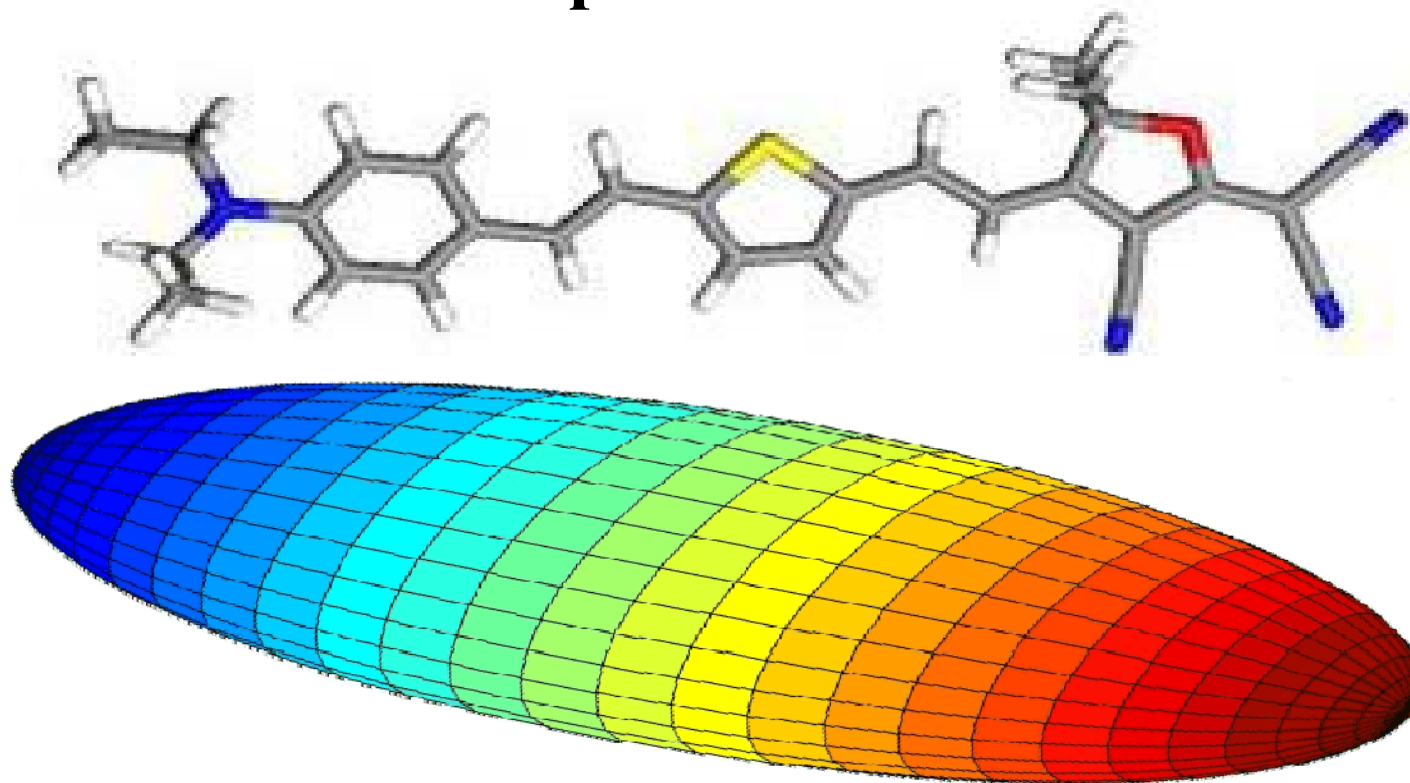

# Monte Carlo Calculations :

- Dipoles are placed at lattice sites (cubic or tetragonal) to build an  $M$  by  $M$  by  $M$  array with  $r$  as nearest neighbor distance.

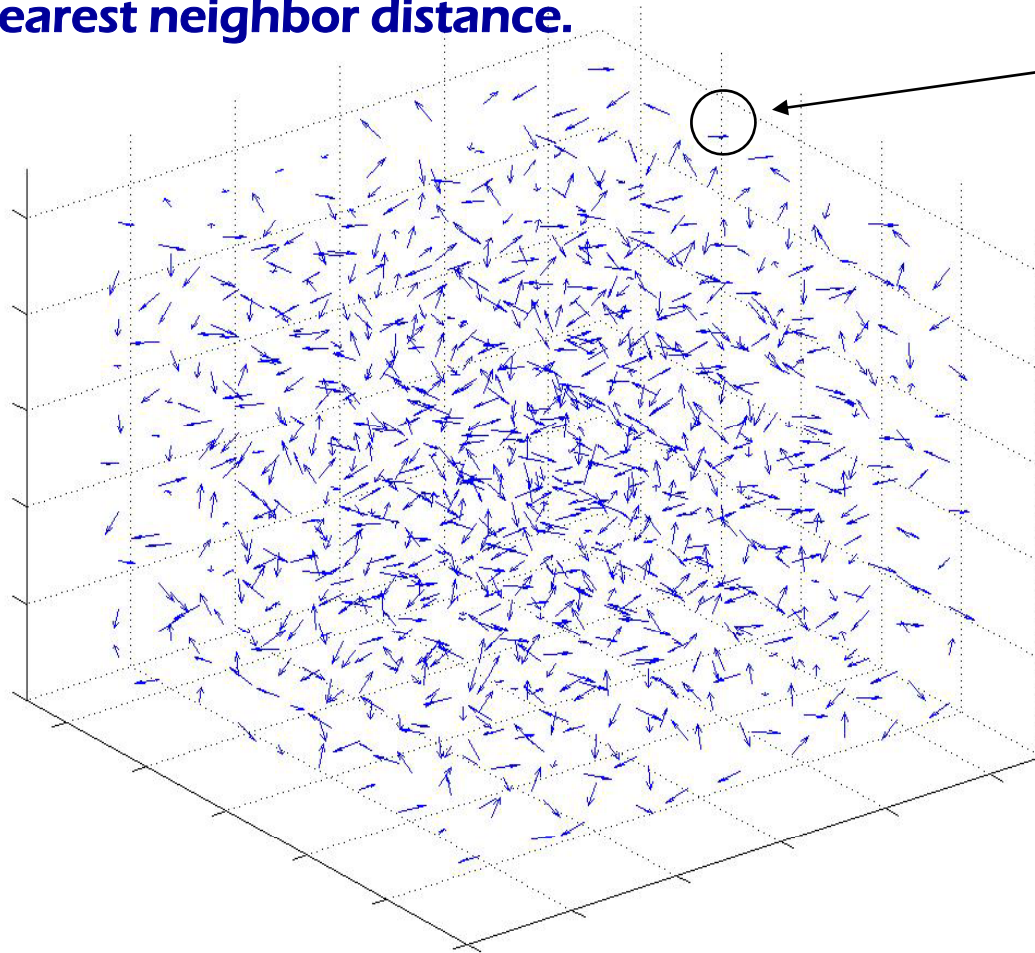

A 10x10x10 random array of dipoles

- Periodic boundary conditions simulate bulk properties while avoiding shape and finite size effects.
- Choose a dipole. Each lattice site is visited once per MC cycle.
- Rotate dipole by: a rotation axis and angle, selected randomly
- Compare the energy before and after rotation.
  - If the energy is lower, keep the move
  - If the energy is higher, compare Boltzmann Probability with a  $[0, 1]$  random number, and keep if larger.
- Repeat for the next lattice site.

# Order under poling

- Compare spheres, 1:2 prolate and 2:1 oblate ellipsoids, and measure order under poling
- Order is same as Langevin at low density and less at high density.

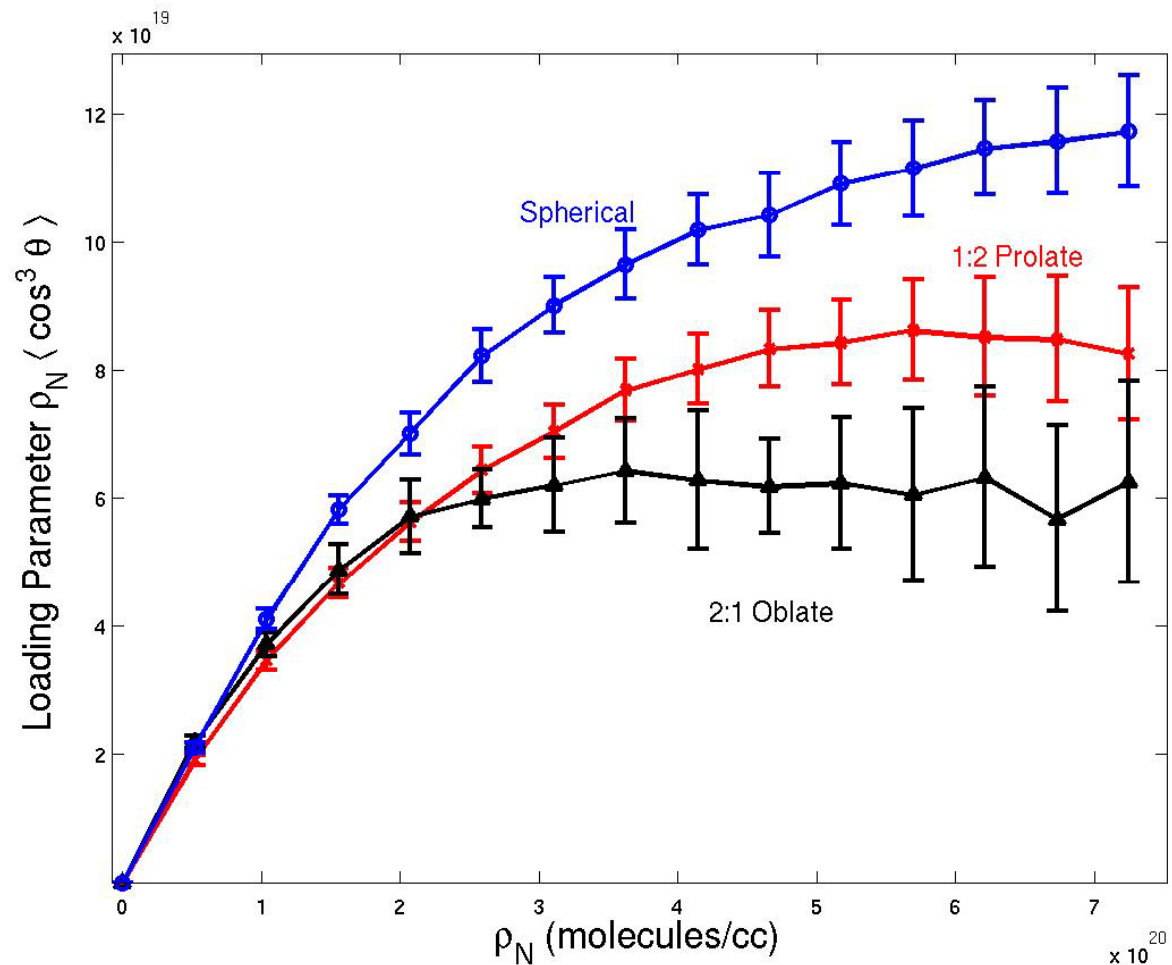

## Order in Systems: e.g. Oblate Spheroids

Each spheroid has a dipole in it pointing on the unique axis (from red to blue side). A poling field is applied on ordinate.

High Density

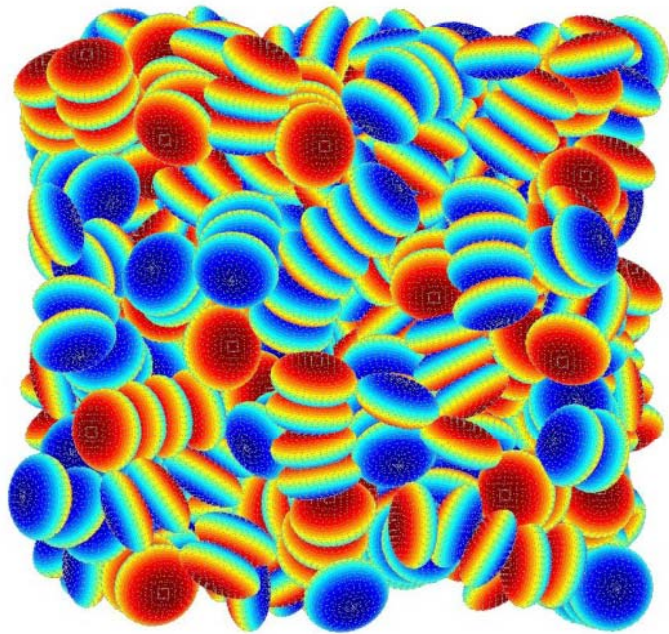

$$\langle \cos^3 \theta \rangle = .1$$

Low Density

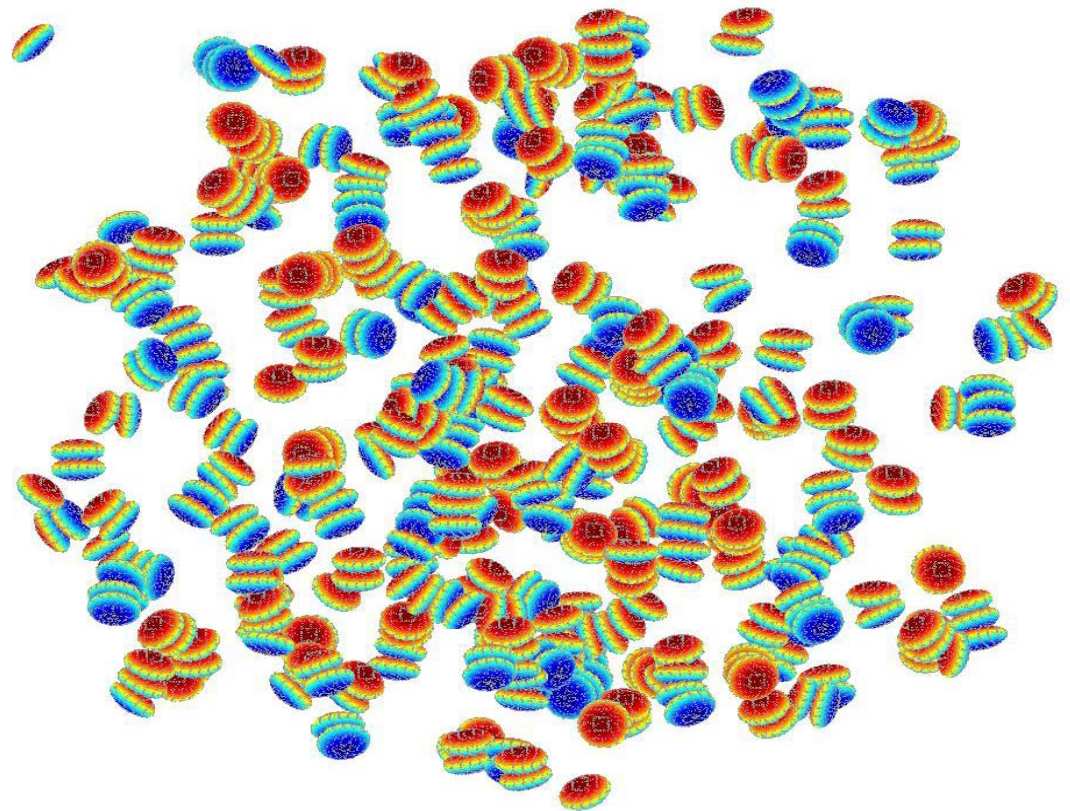

$$\langle \cos^3 \theta \rangle = .4$$

# Complex Macromolecules: Covalent Bond Potentials

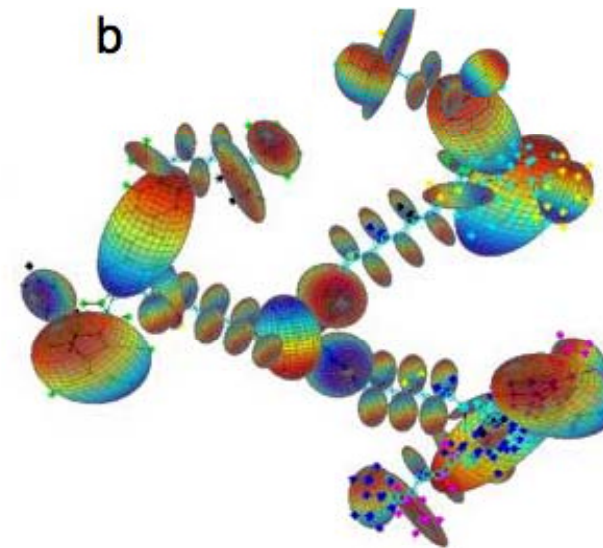
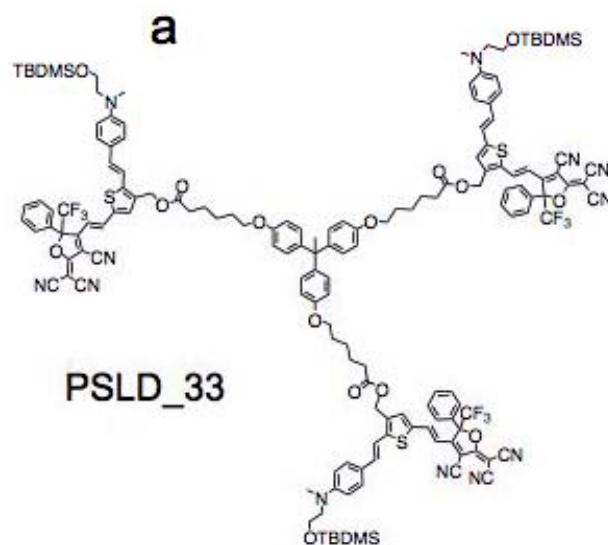
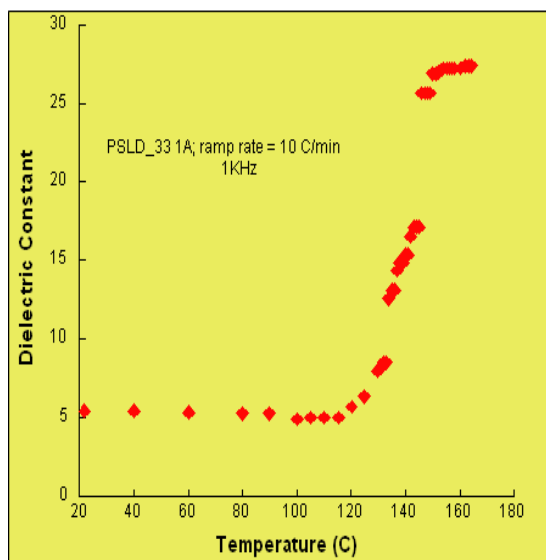

Room temperature dielectric constant;  $\epsilon = 4.8 \pm 0.2$

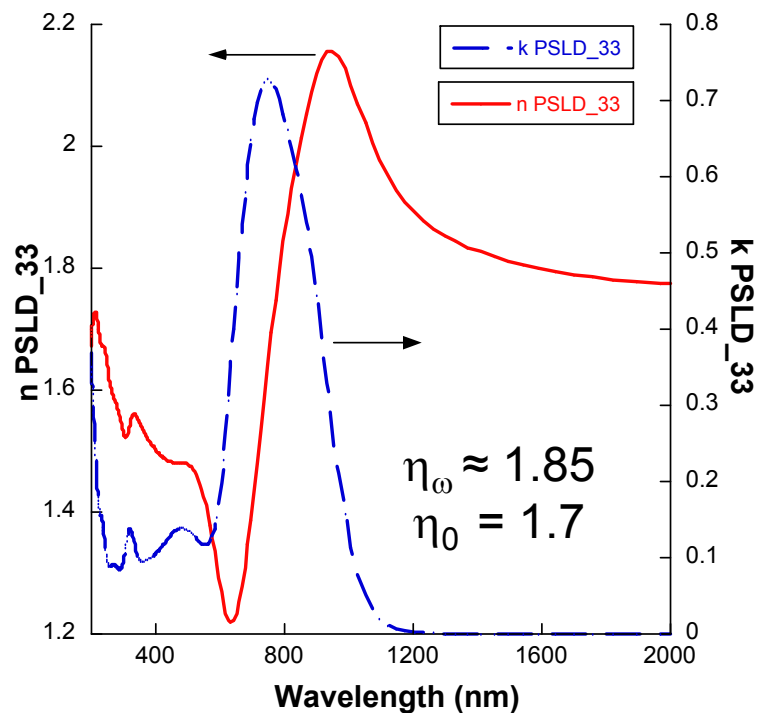
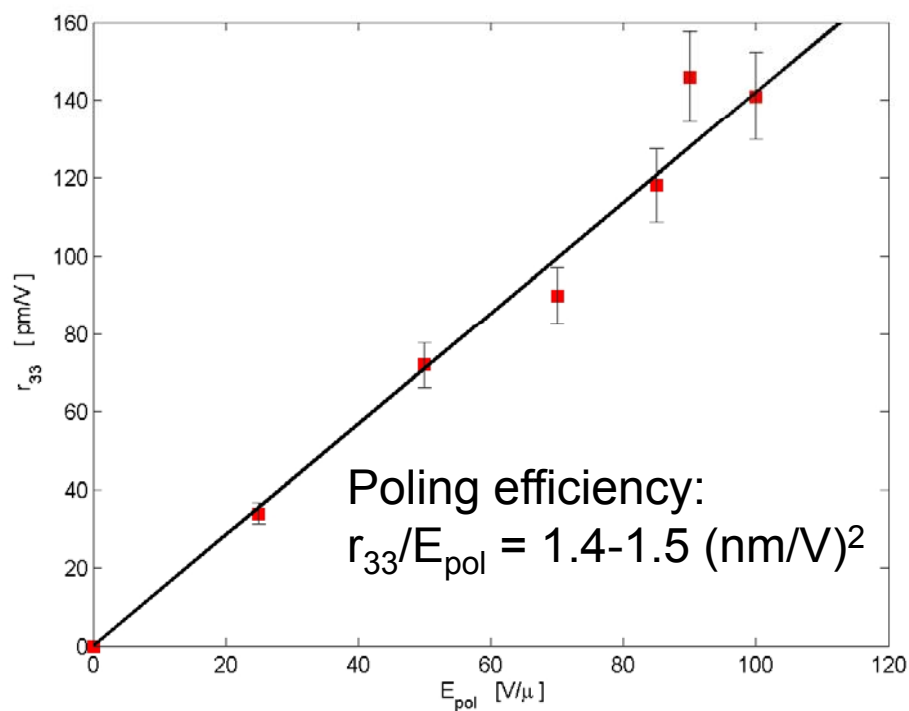

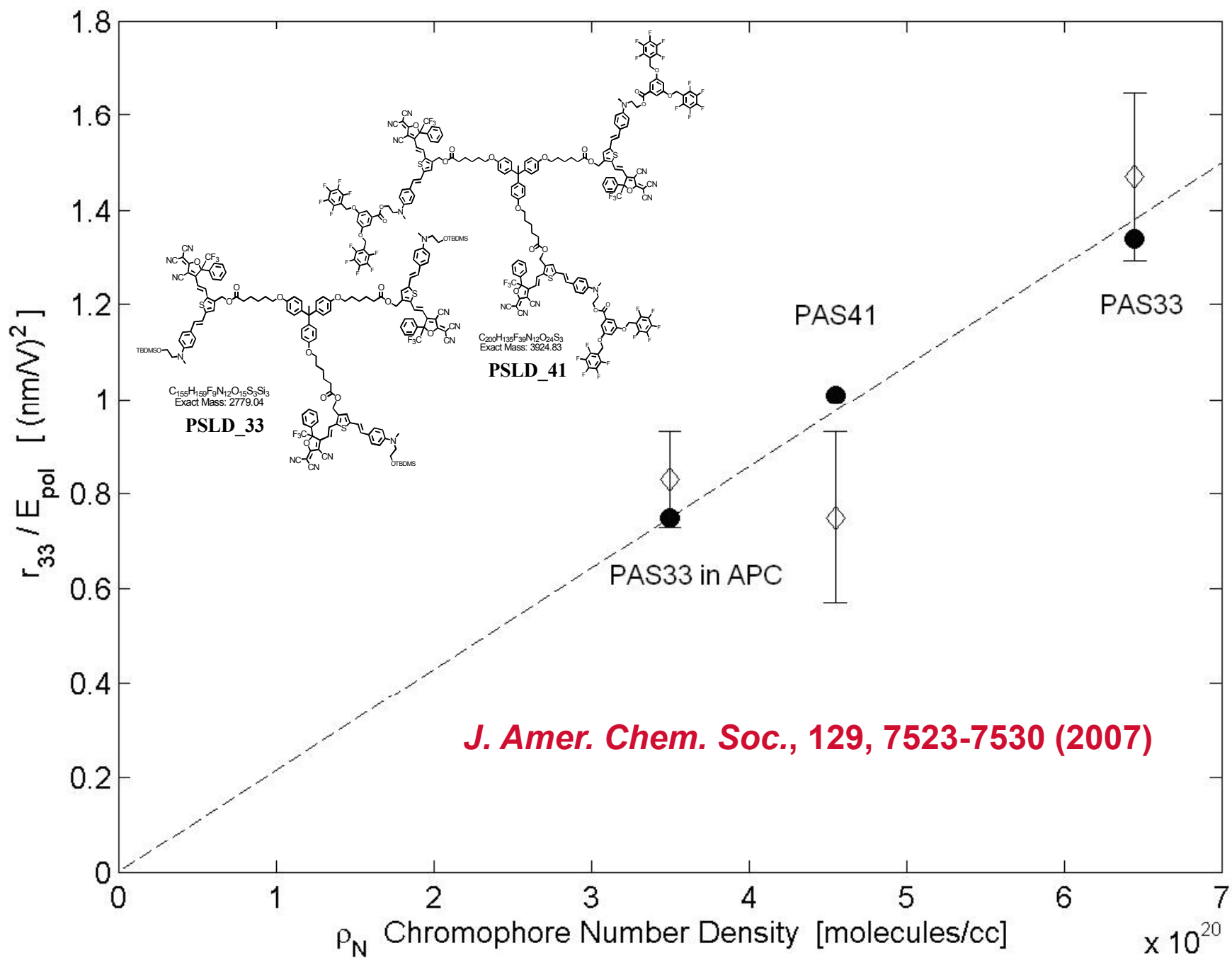

# Conclusions

- ▶ A general prescription now exists for computing an accurate EO coefficient from first principles, with no adjustable parameters.
- ▶ In principle, it should be applicable to any ONLO chromophore in any environment.
- ▶ Results:
  - Dielectric is an extremely important parameter
  - Hyperpolarizabilities are quite large
  - Dipole moments are larger than thought
  - Order is much lower than thought and needs to be improved
- ▶ Efforts to improve order (> 5 fold is possible)
  - Binary Chromophore Mixtures (BCOGs)
  - Laser-Assisted Poling
  - Other strategies to increase order (Influence of Surface)

# Dendrimers & Binary Chromophore Organic Glasses

**YL124**

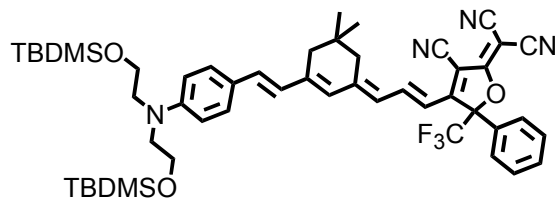

$C_{50}H_{63}F_3N_4O_3Si_2$   
Mol. Wt.: 881.23

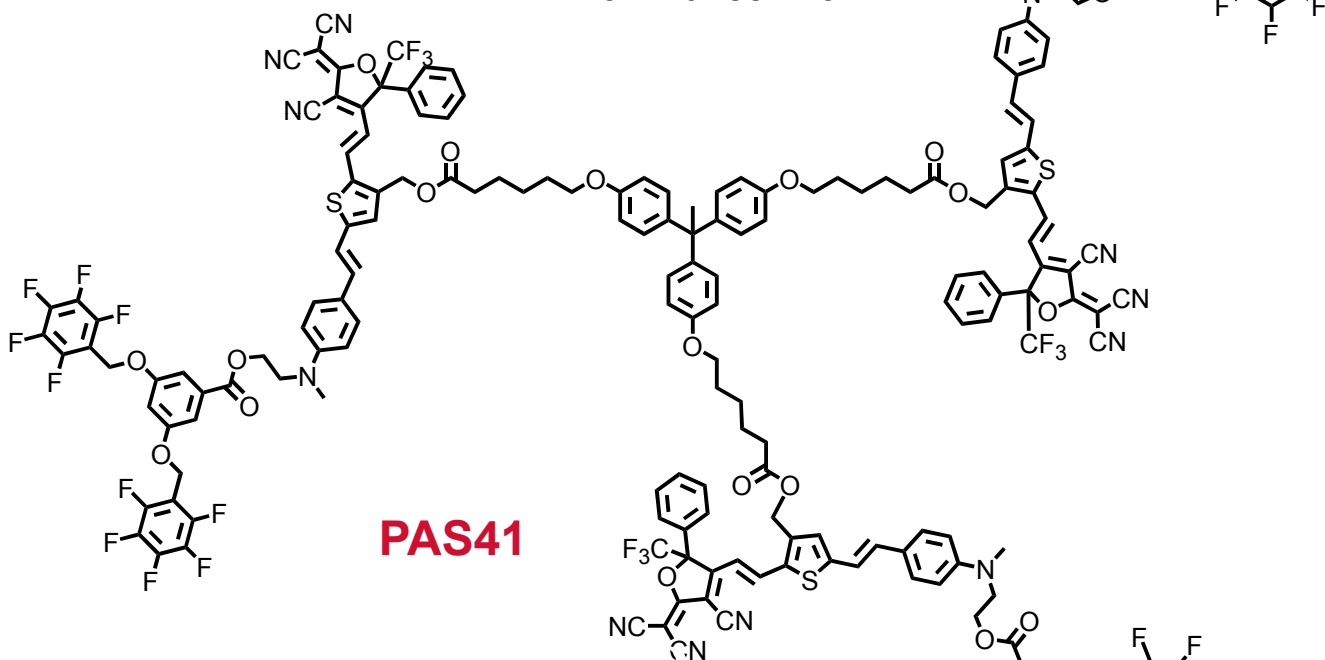

**PAS41**

$C_{200}H_{135}F_{39}N_{12}O_{24}S_3$   
Mol. Wt.: 3927.41

Poling voltage limited to ~ 70 V/micron by conductivity

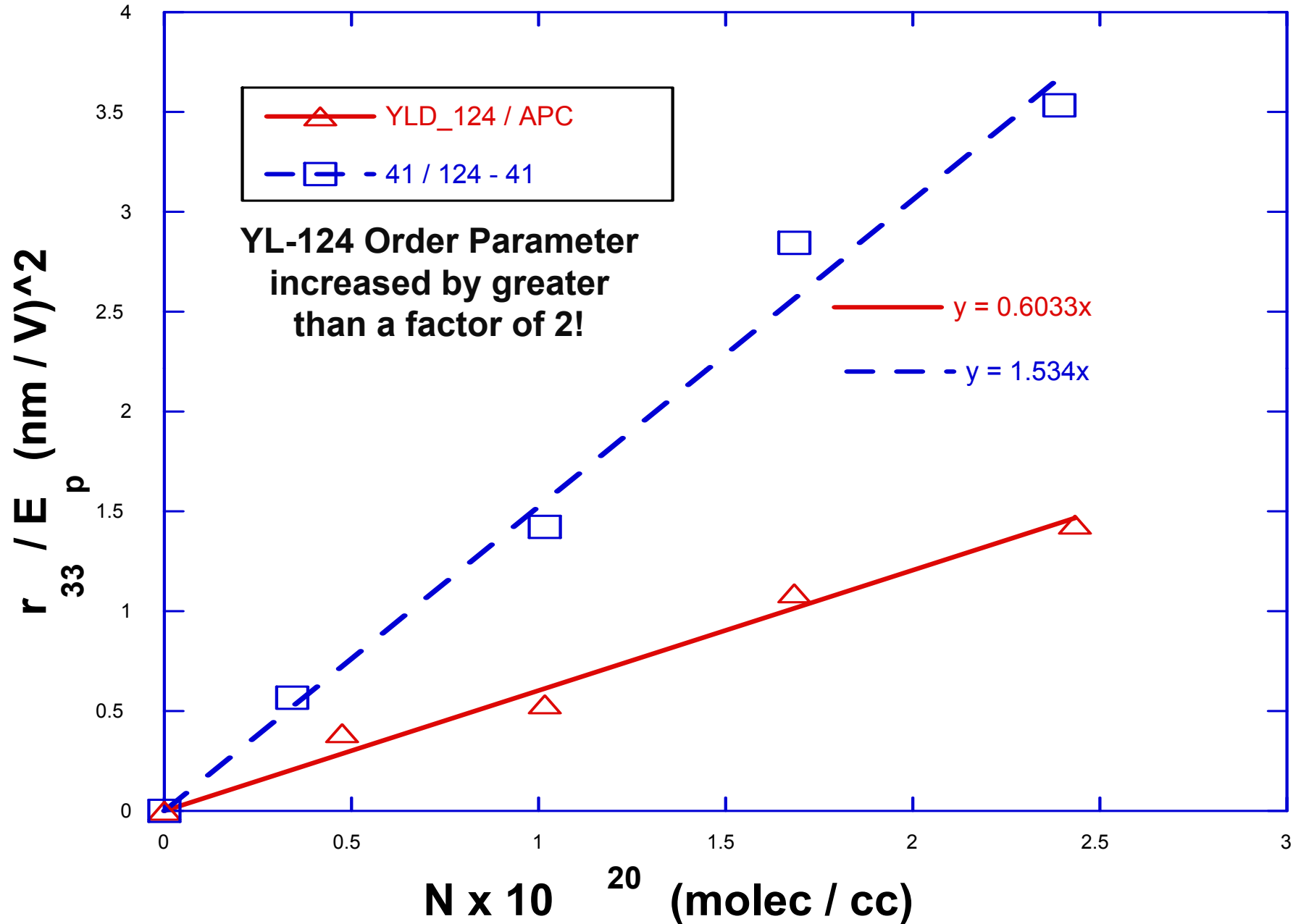

## Comparison of Theory and Experiment

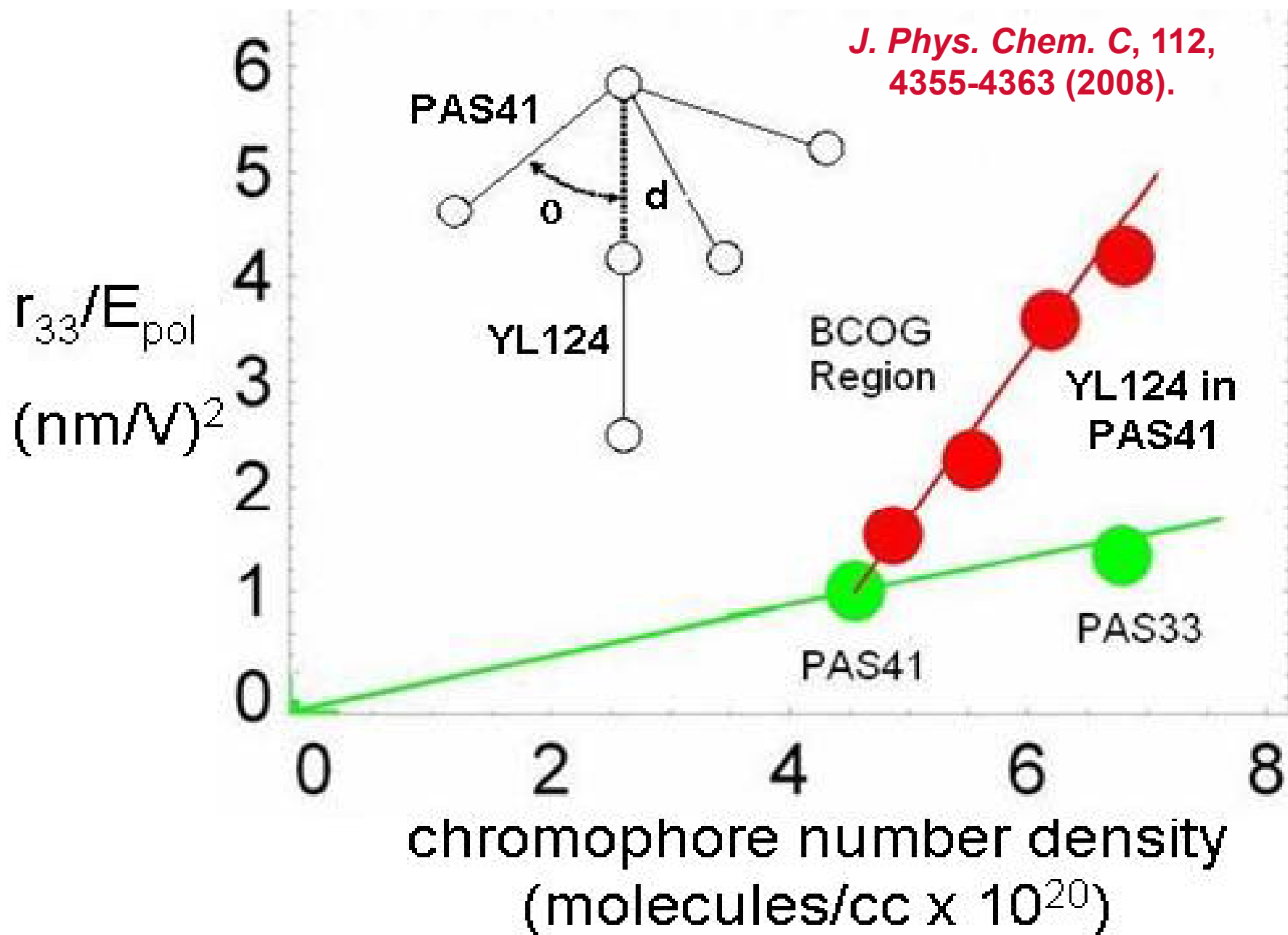

# Key Features of Binary Chromophore Organic Glasses

## Chromophore-Guest/Chromophore-Host Composites

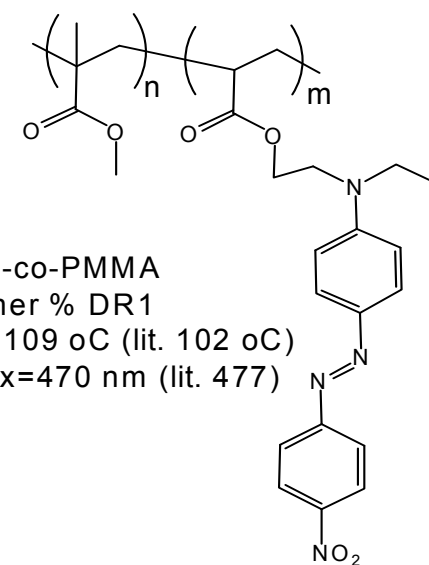
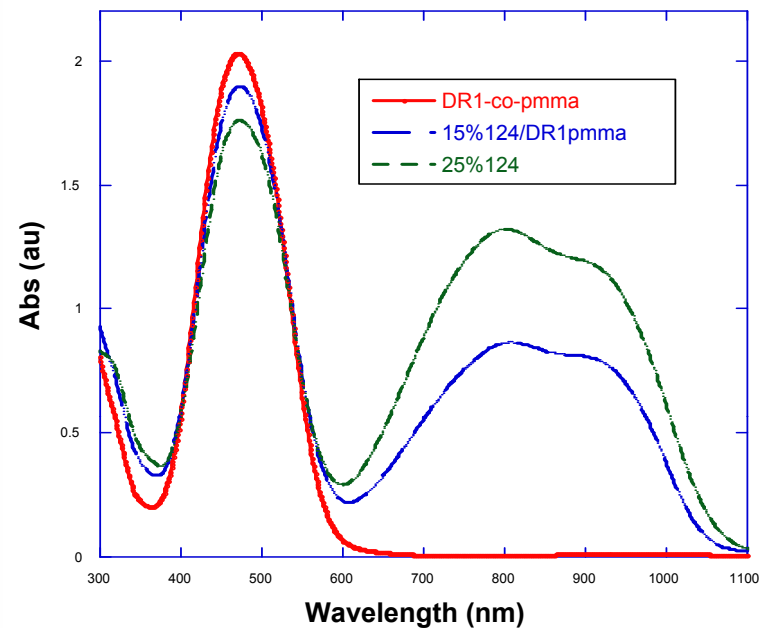
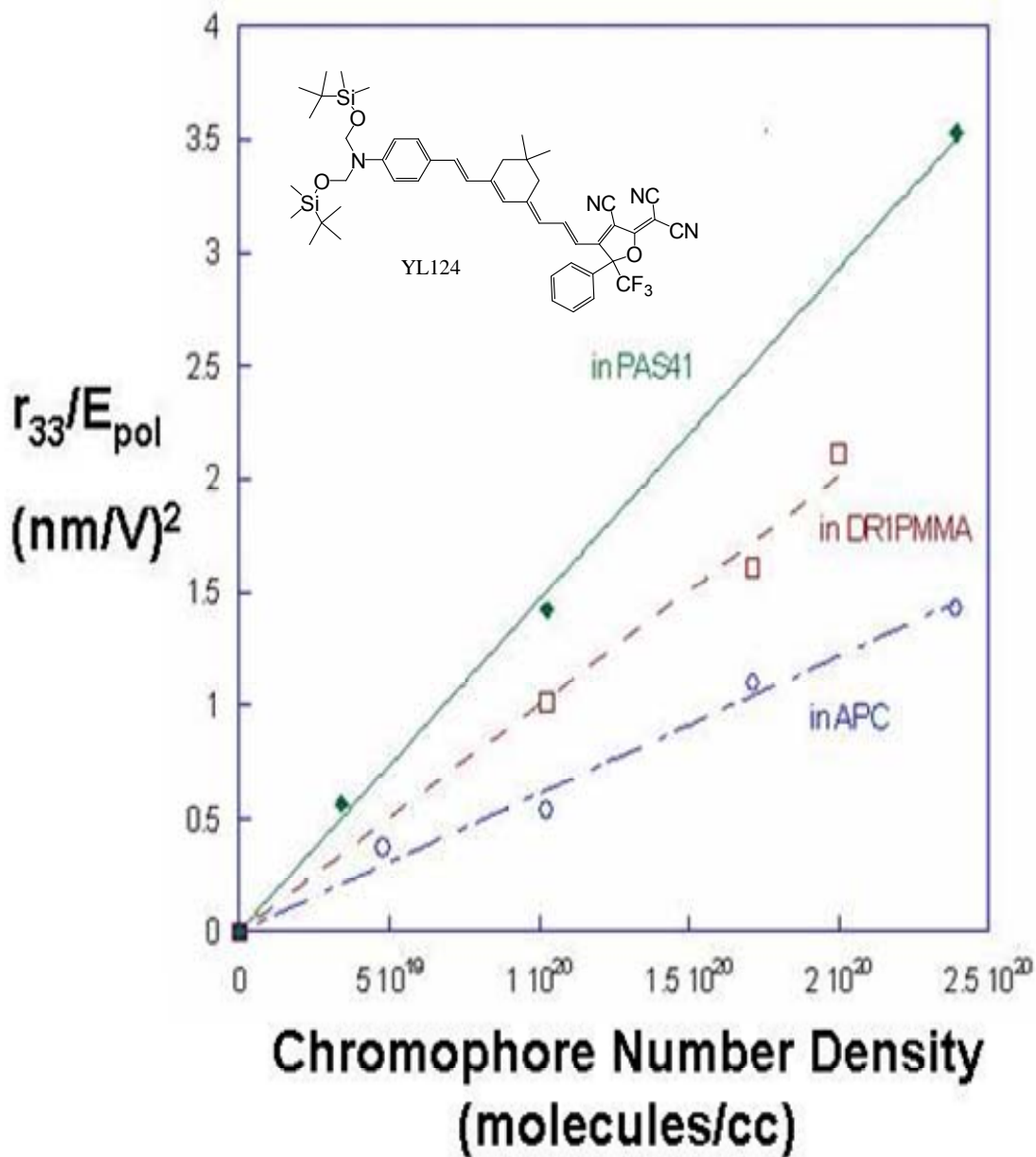

# Laser-Assisted Poling of YLD124 in DR1-co-PMMA

*J. Phys. Chem. C*, 112 (21), 7983-7988  
(2008)

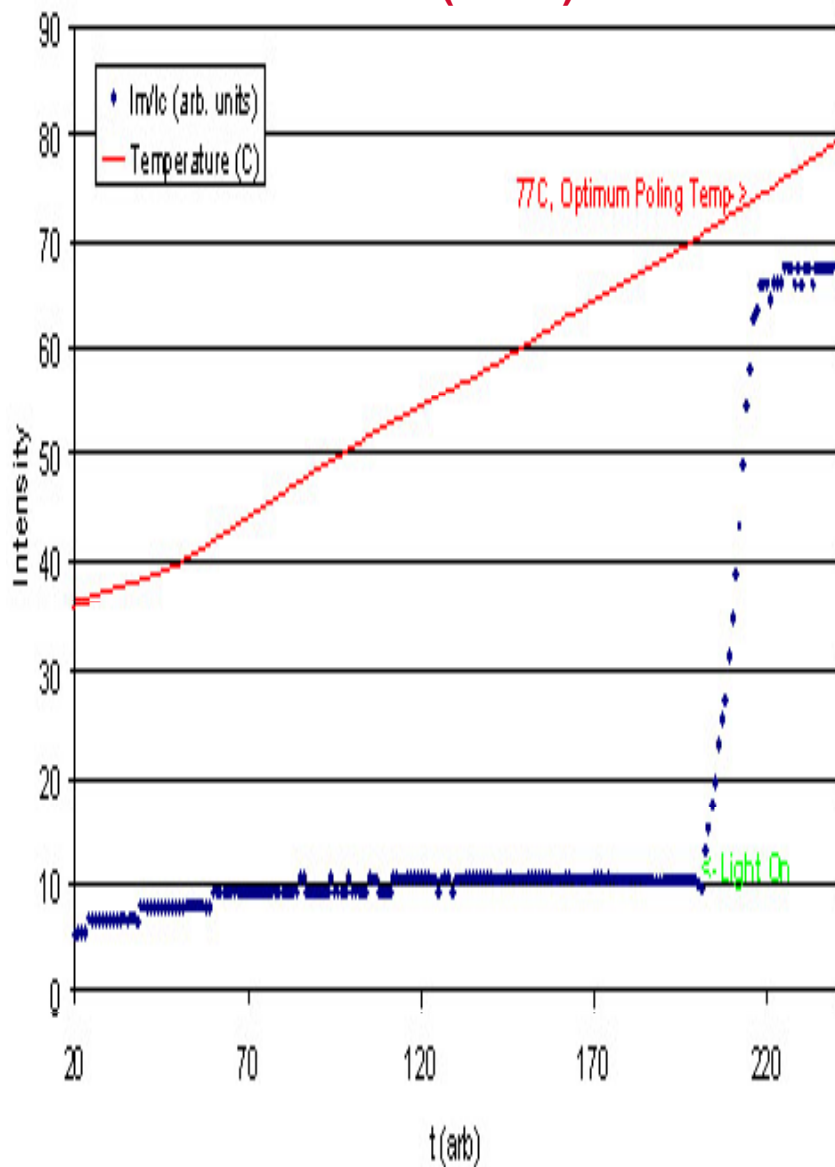

Poling voltage limited by conductivity

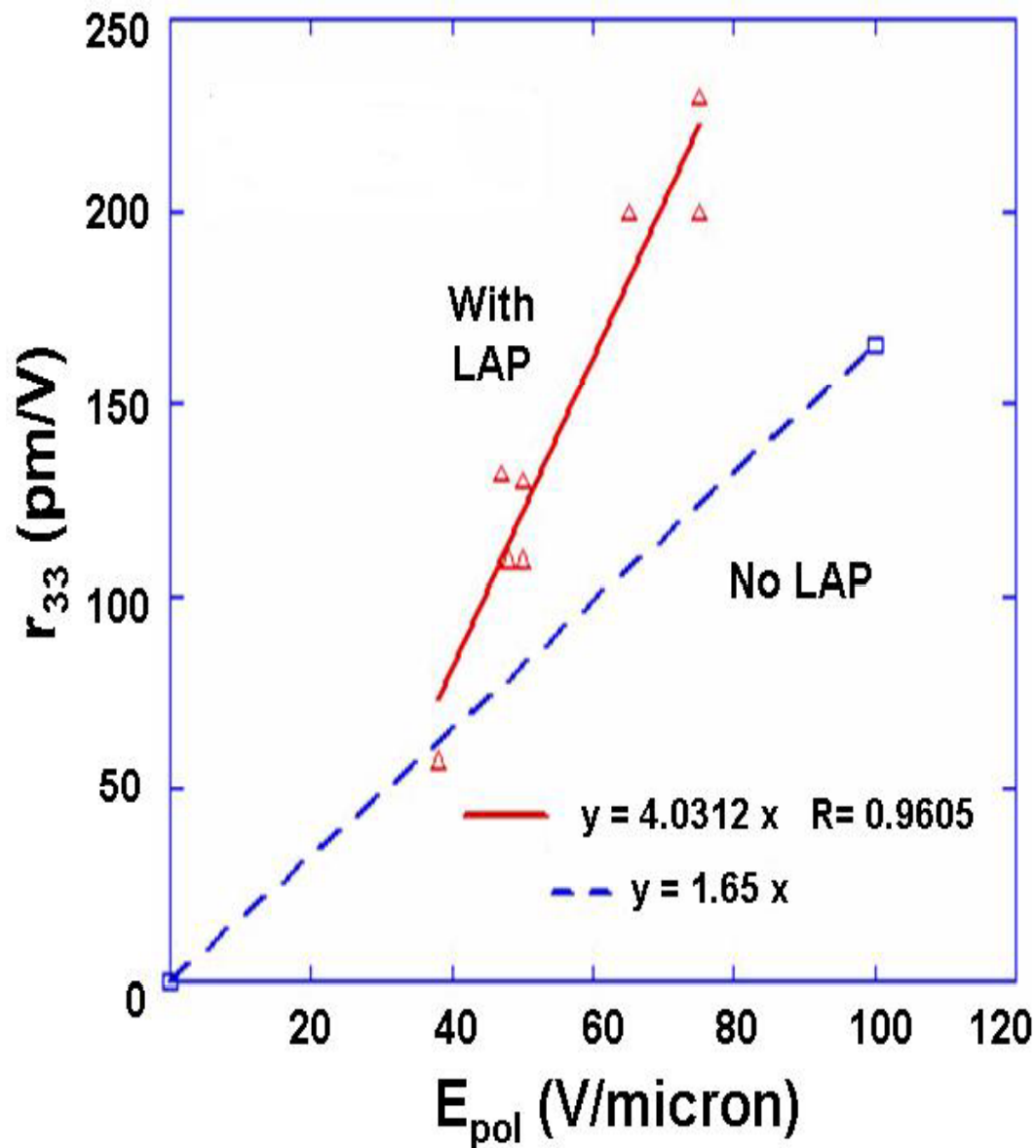

# In-situ LAP apparatus

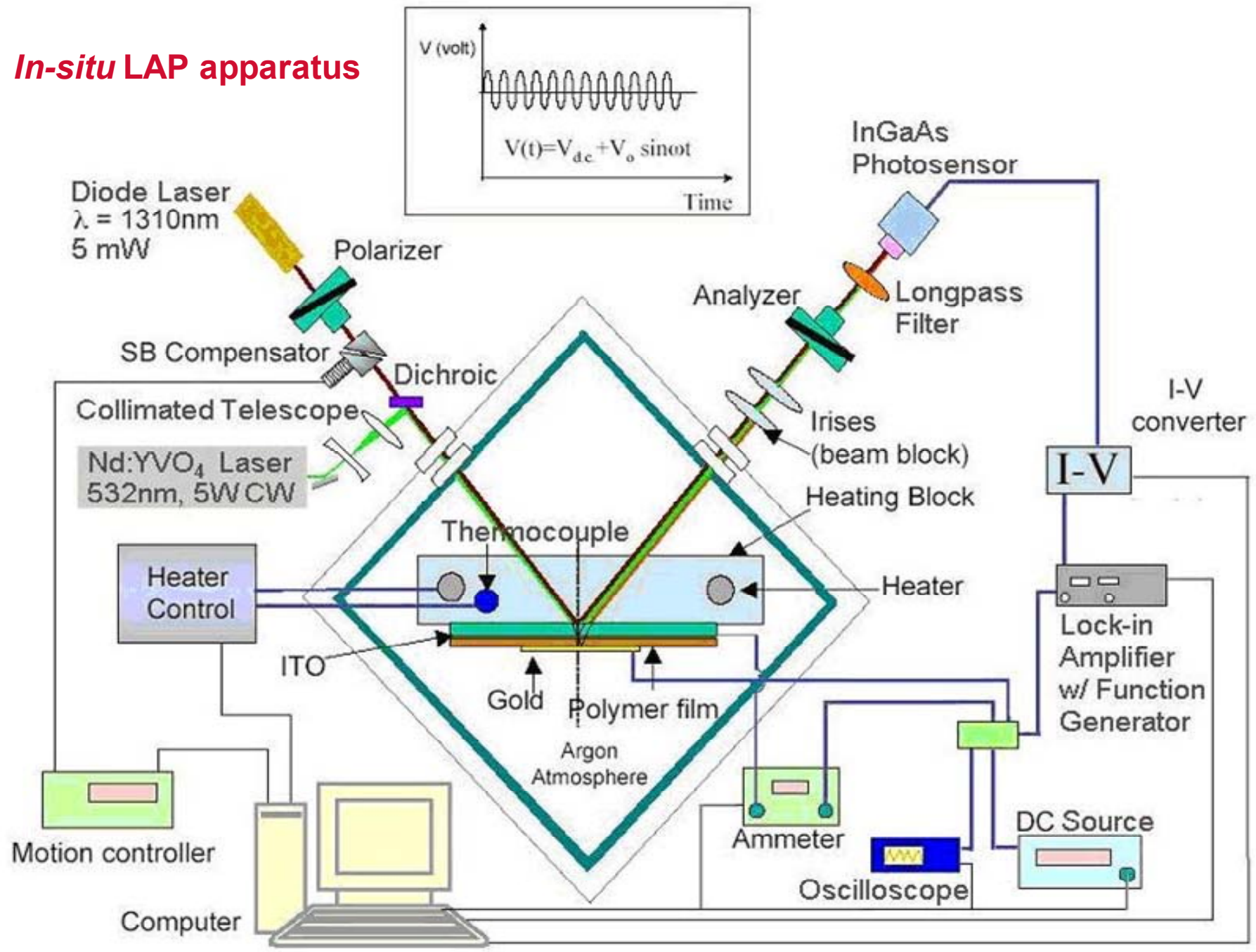

# Measurement of Electro-Optic Coefficients

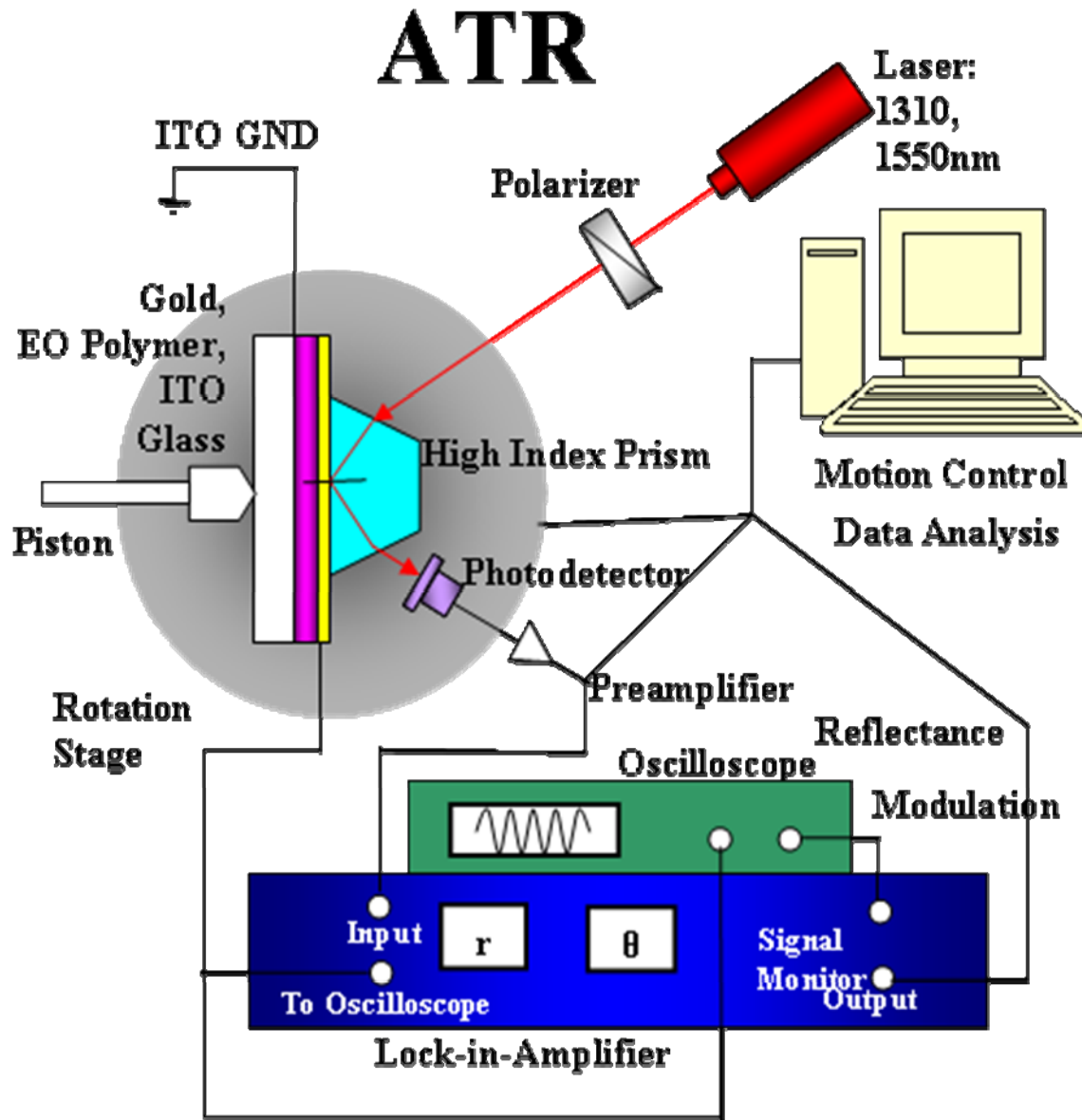

ATR can be used to measure complete EO tensor ( $r_{33}$  and  $r_{13}$ ) at both 1.3 and 1.55  $\mu\text{m}$

Ratio of tensor elements defines order parameter

Avoids potential error associated with indium tin oxide in Teng-Man ellipsometry

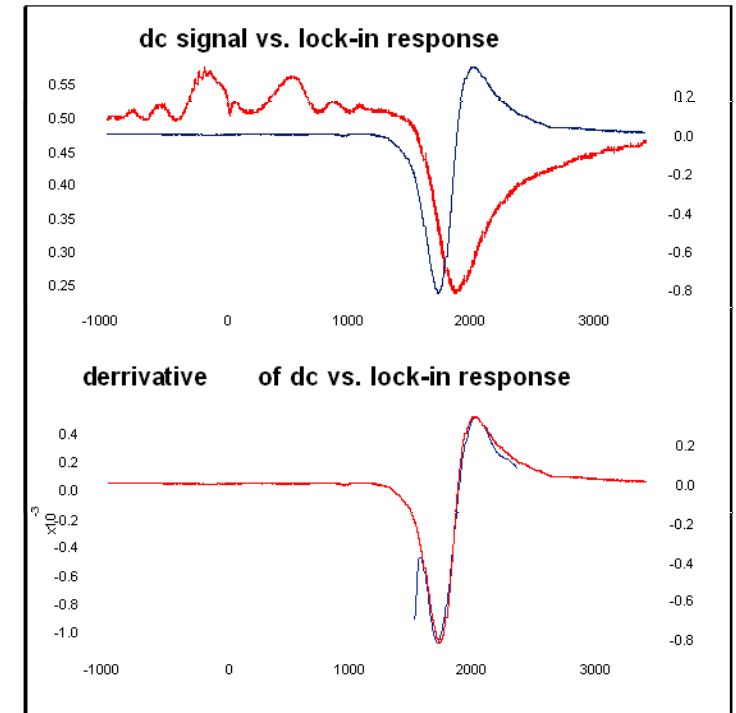

# Variable Angle Polarized Absorption Spectroscopy

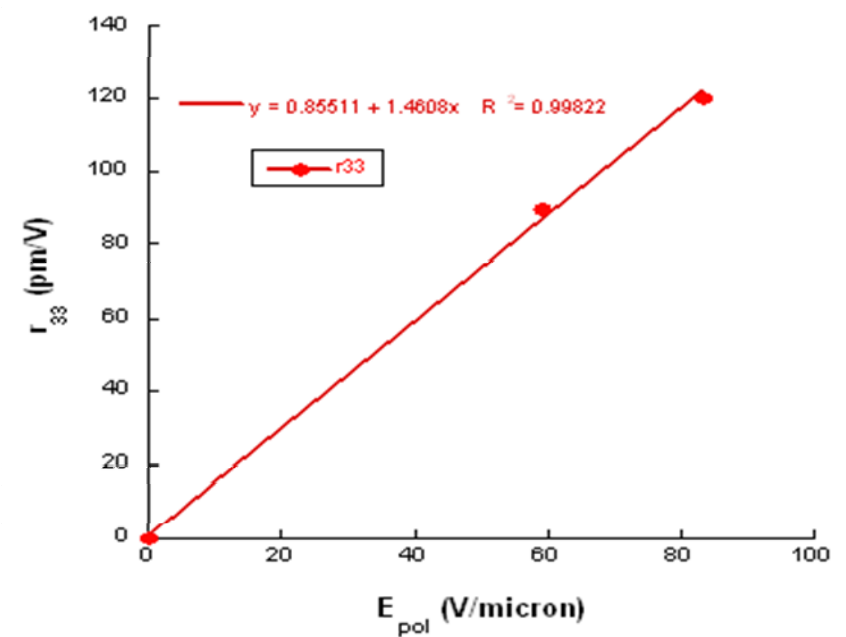
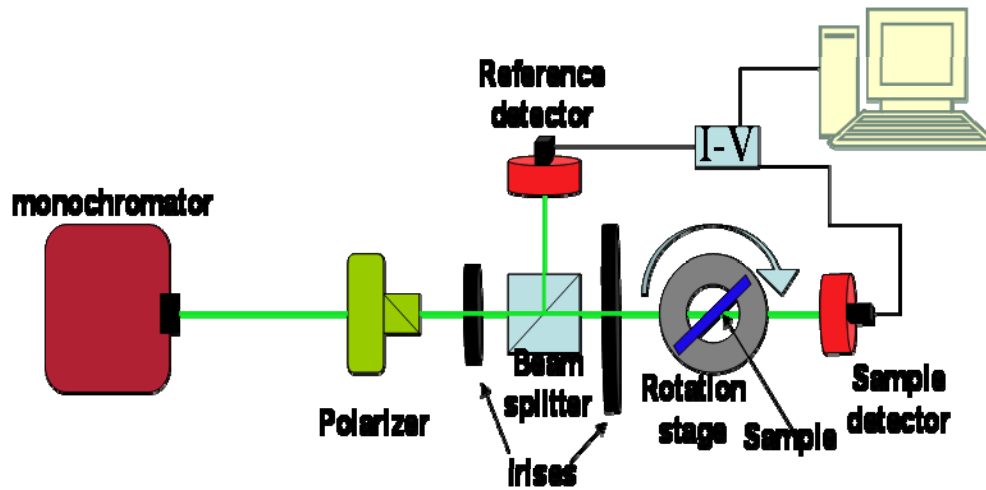

$$\frac{\left\{ \frac{OD + \log T_{frs}}{\ell(\psi) \cdot \log e} \right\}_{poled}}{\left\{ \frac{OD + \log T_{frs}}{\ell(\psi) \cdot \log e} \right\}_{unpoled}} = \left( \frac{\chi_{11}^{\sigma}}{\bar{\chi}} \right) - 3 \langle P_2 \rangle \cdot \cos^2 \psi$$

$$\langle P_2 \rangle \approx \frac{1}{2} \langle \cos^3 \theta \rangle \quad \frac{r_{33}(83V)}{r_{33}(58V)} = \frac{\langle P_2 \rangle(83V)}{\langle P_2 \rangle(58V)} = 1.3$$

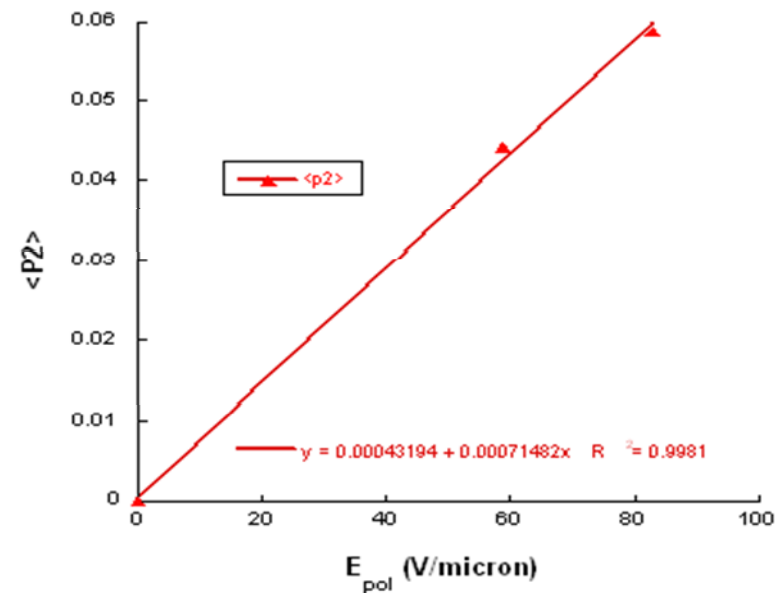

# Summary of Spatially-Anisotropic Forces

- ▶ **Electronic dipole-dipole**
- ▶ **Electric and optical poling field interactions**
- ▶ **Steric (nuclear repulsive) or shape effects including multi-chromophore interactions**
- ▶ **Covalent bond potentials**
- ▶ **Lattice symmetry/surface forces (boundary conditions)**
- ▶ **Quadrupolar**
- ▶ **Hydrogen bonding**
- ▶ **Ionic interactions**
- ▶ **Liquid crystal forces**

**⇒ General Van der Waals interactions are large but not directional. They act to reinforce the above effects.**

# Waveguides: From Silica Fibers to Silicon Nanophotonics

► The **high index of silicon** permits dramatic reduction of waveguide dimensions and the guiding of light around sharp bends (greater flexibility in photonic circuit design)!

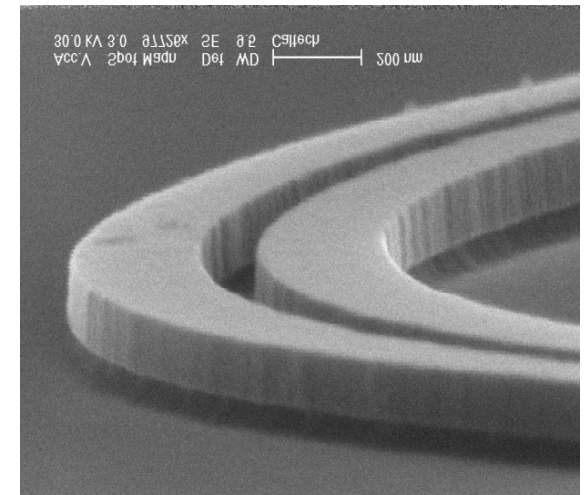
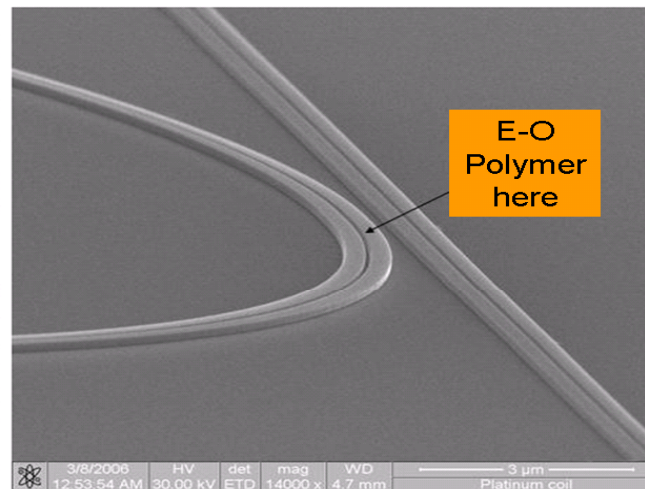
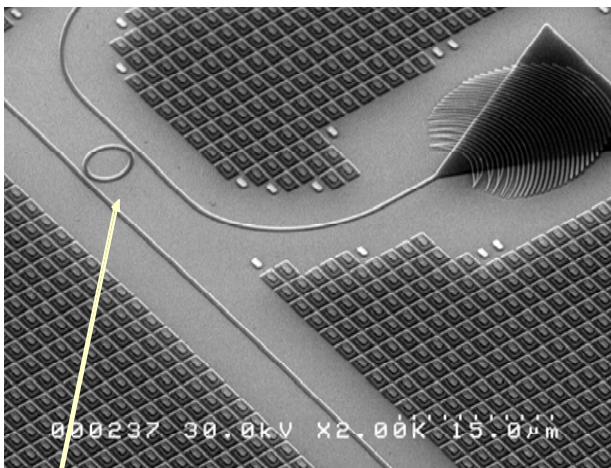
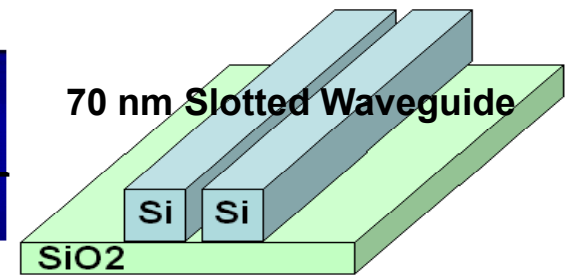
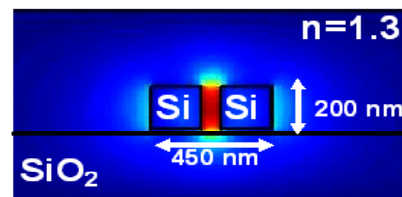
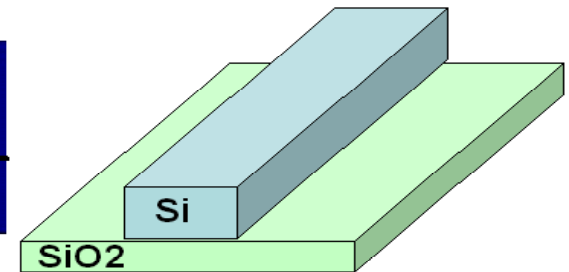
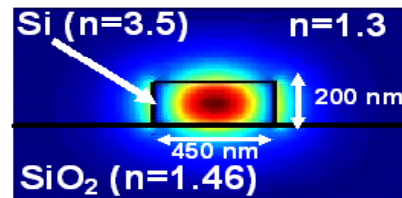
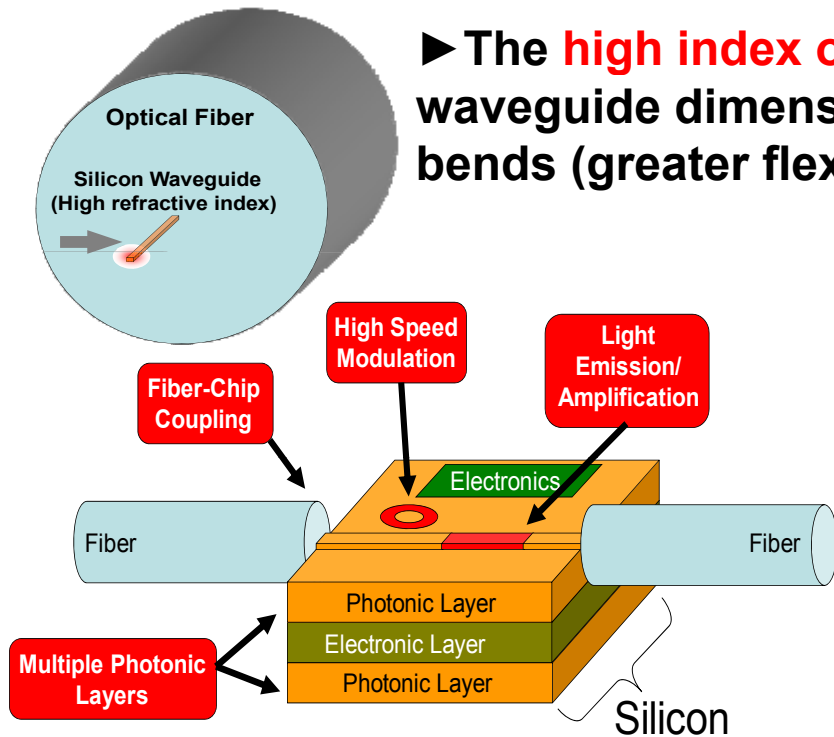

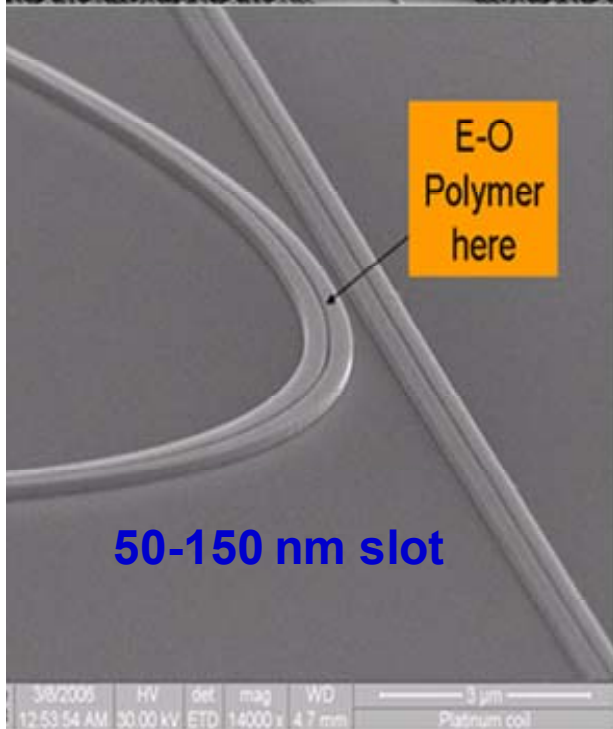
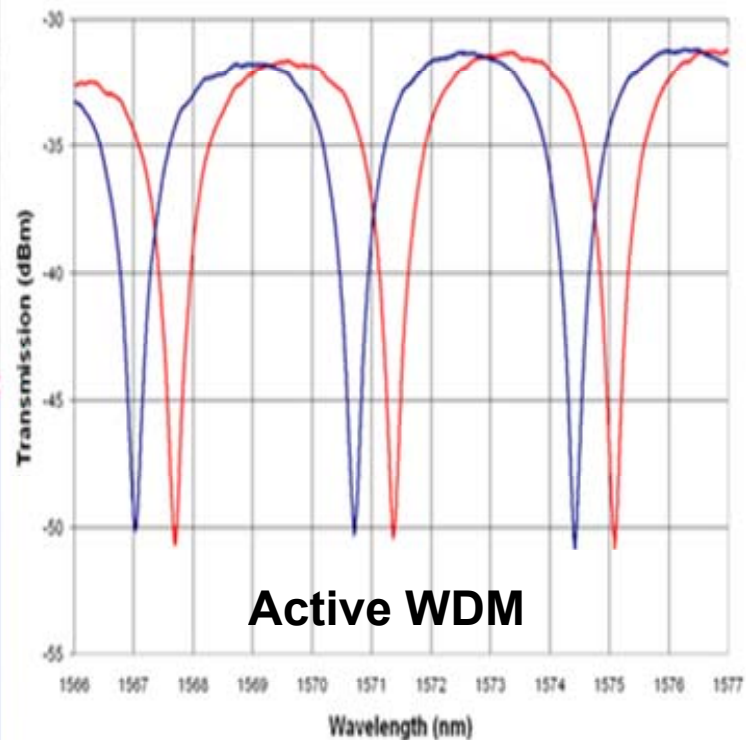
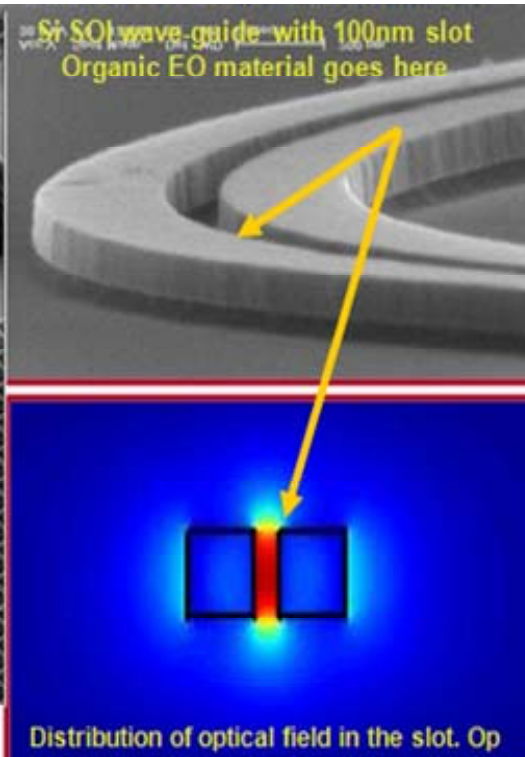
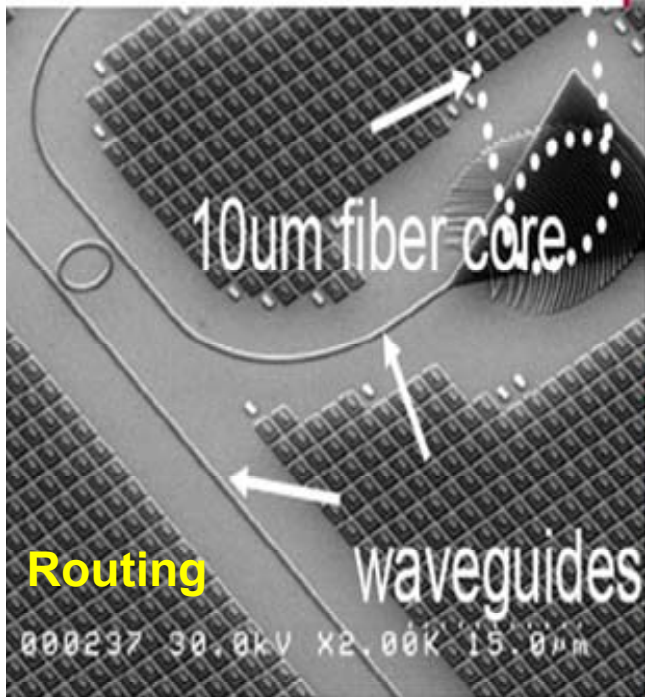

Wavelength Selective Cross-Connect Architectures

JLT,  
in  
press

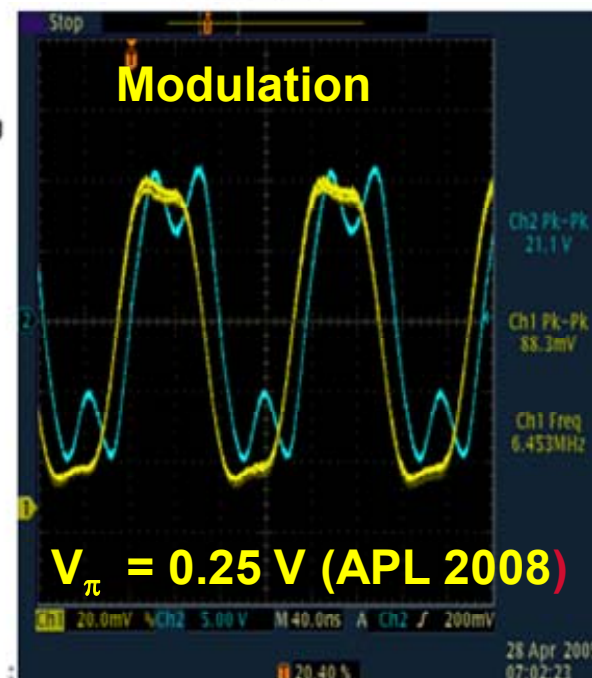
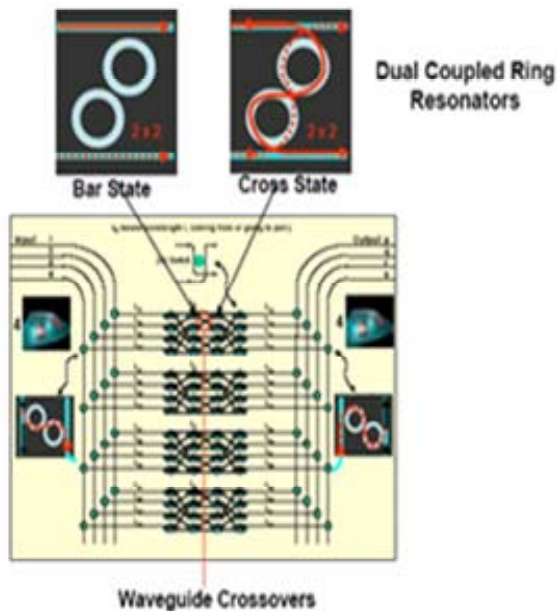

The concentration of Electrical and Optical Fields in Silicon Photonics permits millivolt **electro-optic modulation** ; less than microwatt **optical rectification (photodetection)**, and microwatt **all-optical modulation and switching** (optical computing). In the latter two cases, the bandwidth is on the order of 10 THz

M. Hochberg et al., “All-Optical Modulator in Si with THz Bandwidth,” *Nature Materials*, 5, 703-709 (2006)

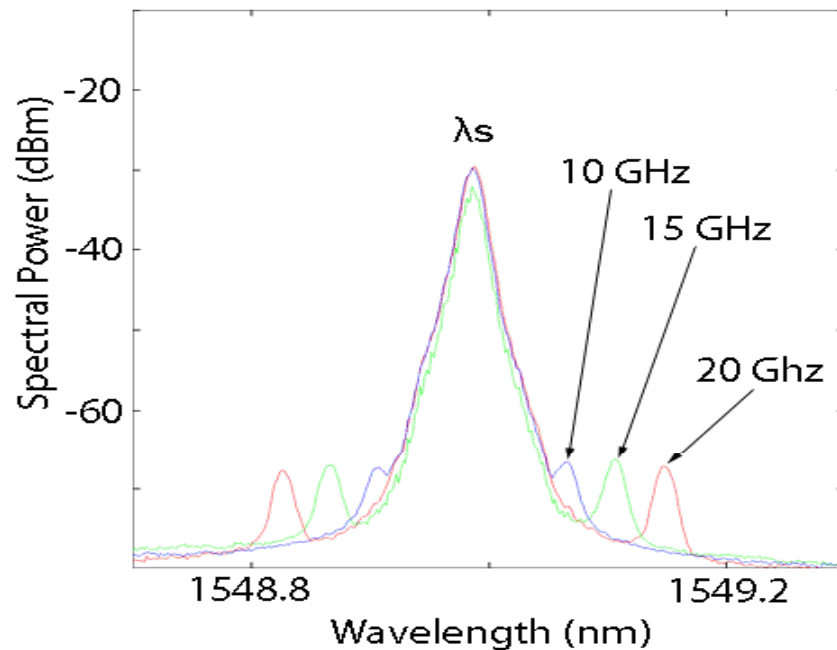
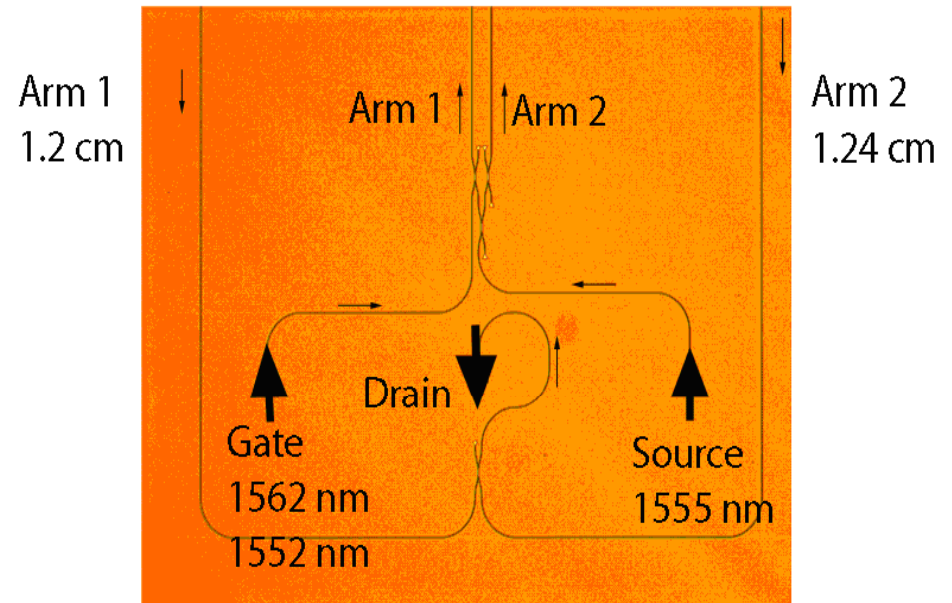

- ▶ **Optical pump power less than 1 mW ( $3 \times 10^6$  V/m)**
- ▶ **1/3 power in organic NLO cladding**
- ▶  **$\chi^{(3)} = 6-7 \times 10^{-21}$  (m/V)<sup>2</sup>**
- ▶ **Modulation to 10 THz**

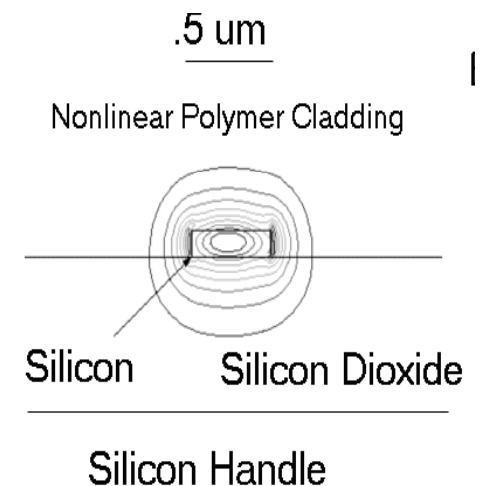

# Competitive EO Technologies



**Lithium Niobate (Fujitsu)**  
**Speed : 40 GHz (2003)**  
**Drive voltage: 1.8V**  
**Insertion loss: 6 dB**



**Charge-Injected Silicon (Intel)**  
**Speed: 40 GHz (2007)**  
**Drive voltage: 4 V**  
**Insertion loss: 19 dB**



**Polymer (Lumera)**  
**Speed: 100 GHz (2006)**  
**Drive voltage: 5 V**  
**Insertion loss: 6 dB**

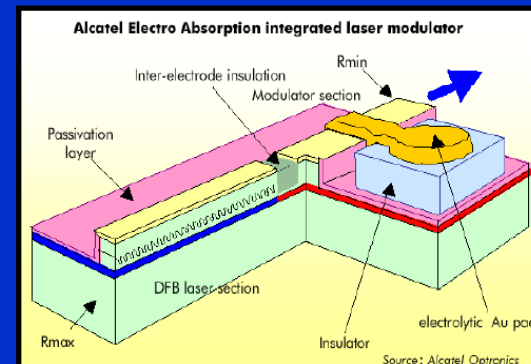
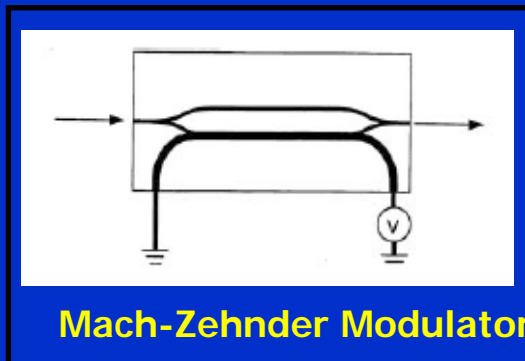

# Effect of Quadrupolar Interactions

Alex Jen

*J. Am. Chem. Soc.* **2007**, *129*, 488.

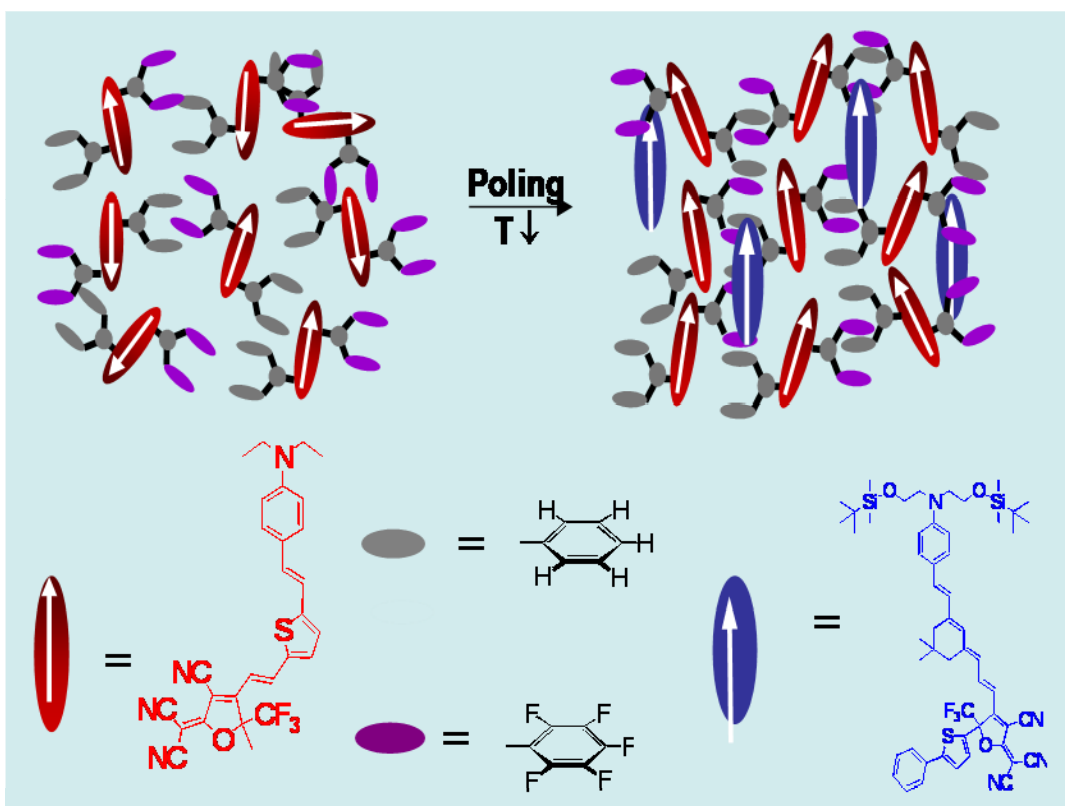

Also lead in to killer problem: **Conductivity!**

$r_{33}$  as high as 327 pm/V

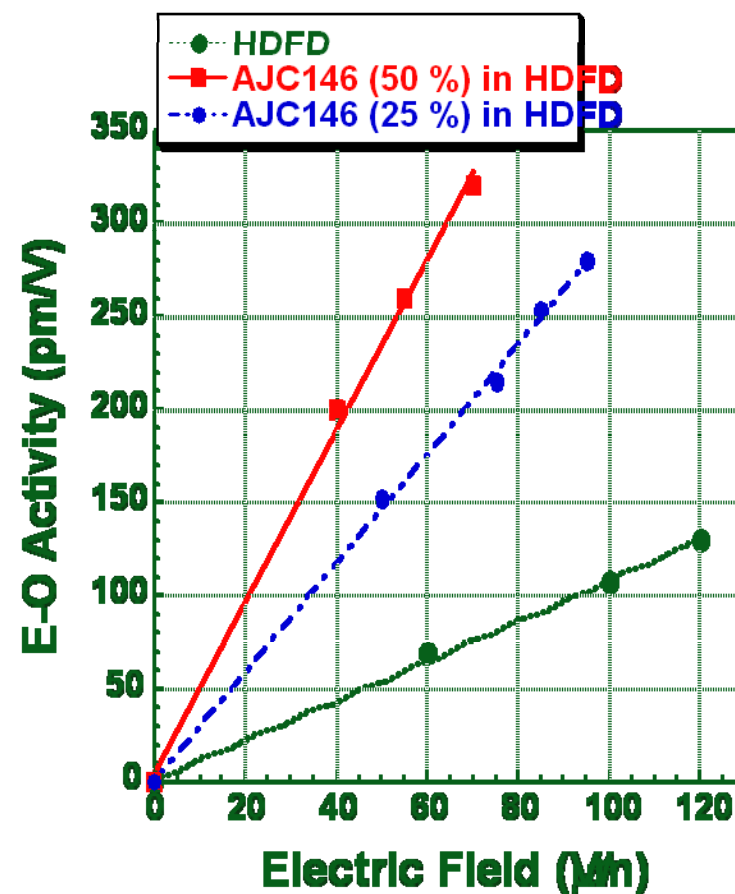

Can use other interactions, e.g., hydrogen bonding, ionic, etc., but want to keep glass transition temperature below decomposition temperature.

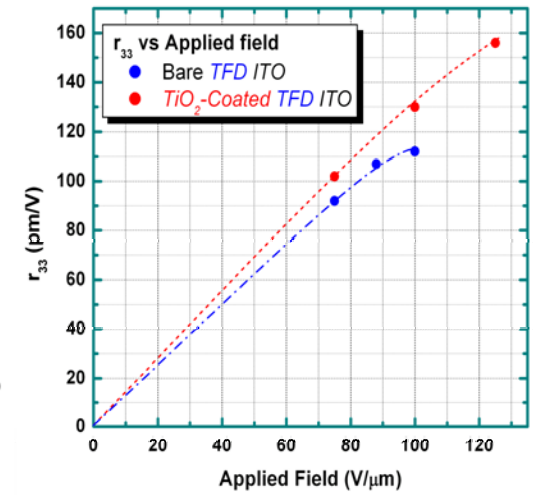
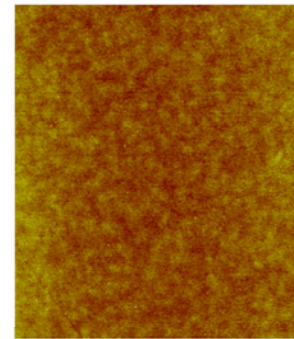
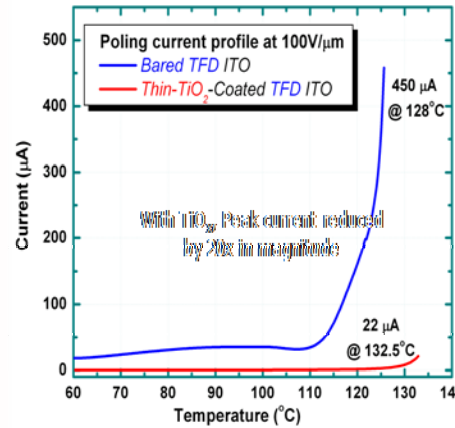
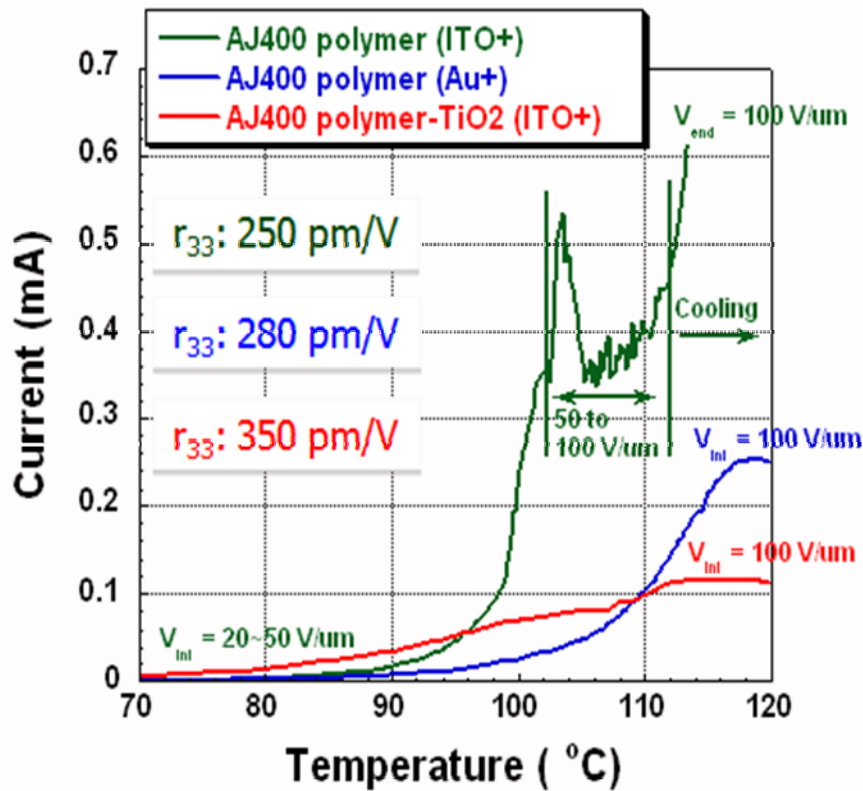

Sol-gel-derived TiO<sub>2</sub> layer

- Low surface roughness
- High dielectric constant
- High conductivity

Improved poling efficiency; good dielectric strength; with the maximum achievable  $r_{33}$  values ~30% higher.

**Paul Ashley and Warren Herman**—Observed increase in poling efficiency with TiO<sub>2</sub> compared to bare ITO but decrease with SiO<sub>2</sub>.

**Ben Olbricht (with A. Jen & T. Marks)**—Enhancement with TiO<sub>2</sub> but worse with Nickel Oxide.

- Bare ITO:  $r_{33}/E_p = 0.59 \text{ (pm/V)/(V}/\mu\text{m)}$
- TiO<sub>2</sub>:  $r_{33}/E_p = 0.83 \text{ (nm/V)}^2$
- NiO:  $r_{33}/E_p < 0.1$

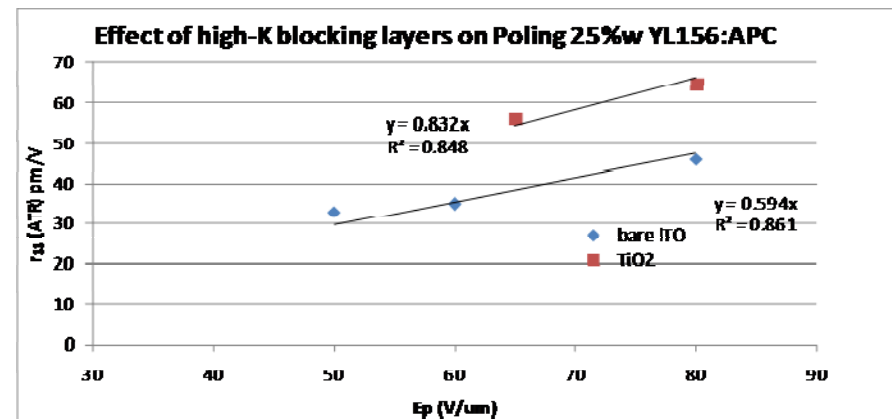

# Improving Thermal Stability Via Diels-Alder Cycloaddition Chemistry

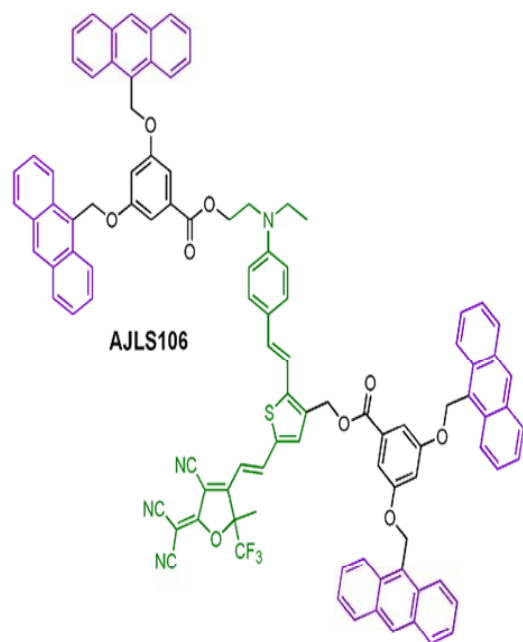
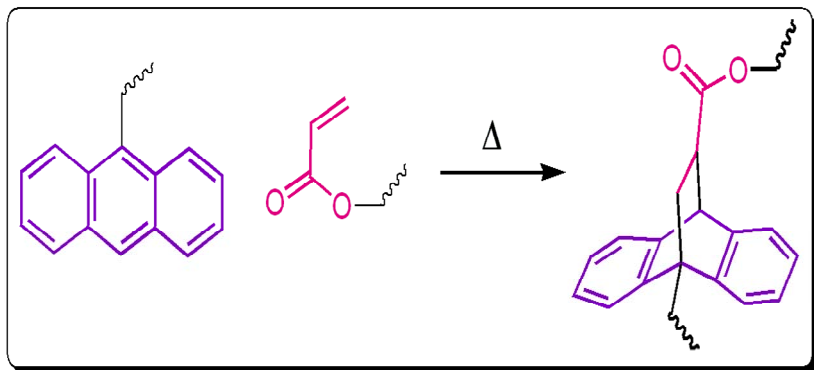

Heating Flow

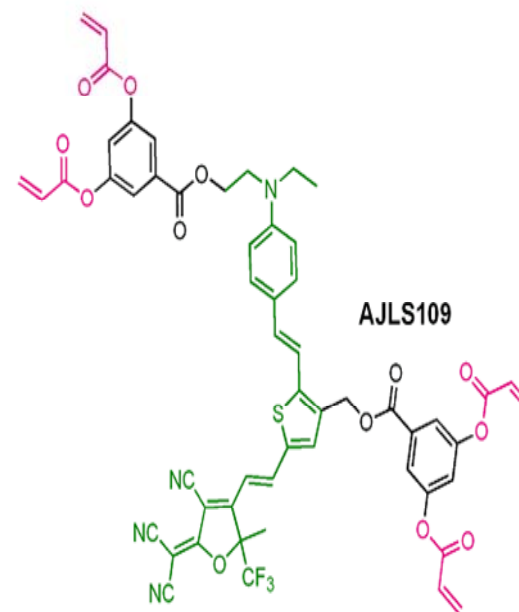
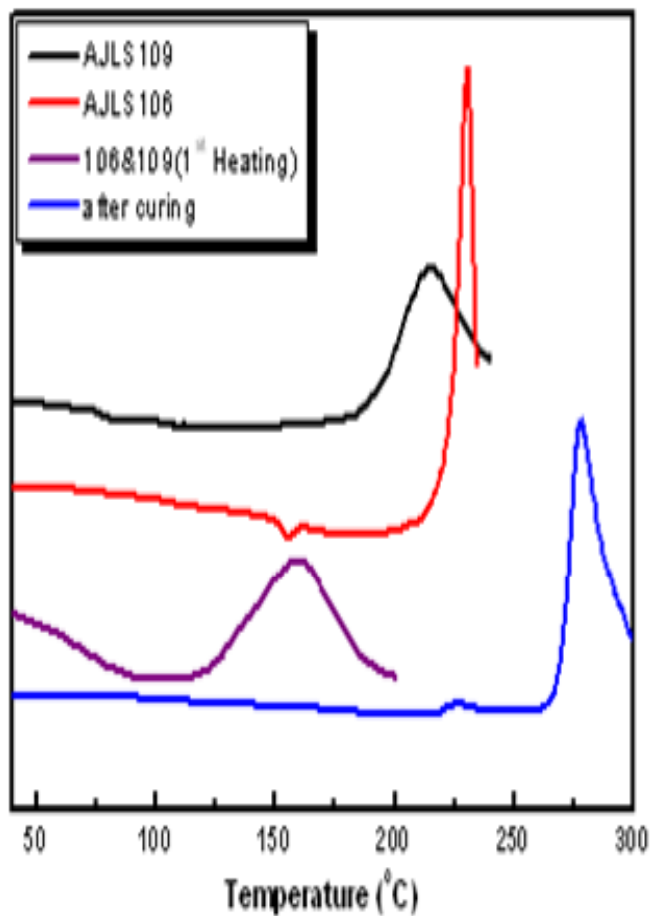

# PHOTODEGRADATION: D2.pas.41

| Sample             | $B/\sigma \times 10^{32} \text{ (m}^{-2}\text{)}$ | $B/\sigma_1 \times 10^{32} \text{ (m}^{-2}\text{)}$ ; contribution | $B/\sigma_2 \times 10^{32} \text{ (m}^{-2}\text{)}$ ; contribution |
|--------------------|---|--|--|
| D2.pas.41          | $37 \pm 7$  | $9 \pm 2$ (17%)  | $82 \pm 60$ (83%)  |
| D2.pas.41 + YLD130 | $13 \pm 3$  | $1.6 \pm 0.2$ (26%)  | $20 \pm 12$ (74%)  |
| D2.pas.41 + YLD124 | $28 \pm 7$  | $5 \pm 2.5$ (23%)  | $49 \pm 20$ (77%)  |
| YLD124 in APC      | $5 \pm 2$   | $0.5 \pm 0.2$ (59%)  | $6 \pm 2$ (41%)  |

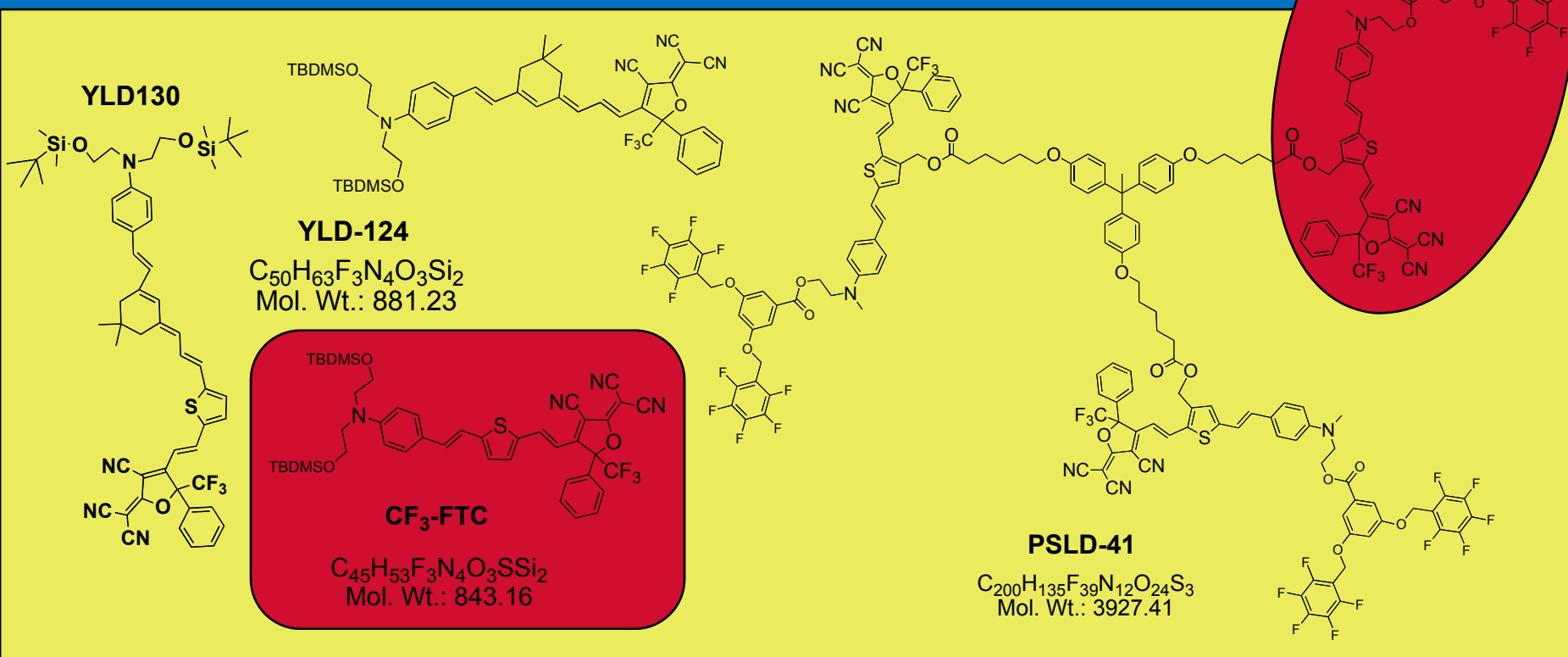

## Other important proof-of-concept studies

### ◆ Model System Studies

-- Yi Liao, Kimberly A. Firestone, Sanchali Bhattacharjee, Jingdong Luo, Marnie A. Haller, Steven Hau, Cyrus A. Anderson, David Lao, Bruce E. Eichinger, Bruce H. Robinson, Philip J. Reid, Alex K.-Y. Jen, and Larry R. Dalton, "Linear and Nonlinear Optical Properties of a Macrocyclic Trichromophore Bundle with Parallel-Aligned Dipole Moments," *J. Phys. Chem. B*, 110, 5434-5438 (2006).

-- Yi Liao, Sanchali Bhattacharjee, Kimberly A. Firestone, Bruce E. Eichinger, Ranja Paranj, Cyrus A. Anderson, Bruce H. Robinson, Philip J. Reid, and Larry R. Dalton "Antiparallel-Aligned Neutral-Ground State and Zwitterionic Chromophores as a Nonlinear Optical Material," *J. Am. Chem. Soc.*, 128, 6847- 6853 (2006).

### ◆ LB Sequential Assembly Studies

-- Michael Halter, Yi Liao, Ryan M. Plocinik, David C. Coffey, Sanchali Bhattacharjee, Ursula Mazur, Garth J. Simpson, Bruce H. Robinson, and Sarah L. Keller, "Molecular Self-Assembly of Mixed High-Beta Zwitterionic and Neutral Ground-State NLO Chromophores," *Chem. Mater.*, 20, 1778-1787 (2008).

◆ **What Should be Possible:**  $r_{33} = 1000$  pm/V;  $< 2$  dB/cm loss;  
 $T_g > 200^\circ\text{C}$ ;  $B/\sigma > 500 \times 10^{32}$  m<sup>-2</sup> (ten year photostability)



**Thank you  
for your  
attention**